



Moscow International School of Physics

HSE Study Center "Voronovo", 20-27 February 2019

Introduction to Machine Learning

Fedor Ratnikov

Moscow International School of Physics



SCHOOL OF DATA ANALYSIS

NRU Higher School of Economics,
Yandex School of Data Analysis

1941
Andrei Tatarskiy

What to Expect

- ◇ This is not a practical introduction into Machine Learning
 - ◇ There are many practical courses available:
 - ◇ <https://www.coursera.org/learn/machine-learning>
 - ◇ <https://www.coursera.org/specializations/machine-learning>
 - ◇ International ML school driven by HSE and dedicated to applying ML to HEP related problems, MLHEP:
 - ◇ <https://github.com/yandexdataschool/mlhep2018>
 - ◇ <https://github.com/yandexdataschool/mlhep2017>
 - ◇ <https://github.com/yandexdataschool/mlhep2016>
- ◇ The goal of these lectures is to present basic ML ideas and foundations
 - ◇ what may and may not be expected from ML applications.

Credits

- ◇ This presentation have been prepared with a great use of well established academic courses and ideas from
 - ◇ K. Vorontsov
 - ◇ <http://www.machinelearning.ru/wiki/index.php?title=Участник:Vokov>
 - ◇ A. Artemov
 - ◇ <https://www.hse.ru/en/org/persons/200432883>
 - ◇ A. Rogozhnikov
 - ◇ <http://arogozhnikov.github.io>
- ◇ ... with a great assistance from A. Panin

Outlook

- ◇ Models and data
- ◇ Formal set of the ML problem
- ◇ Practical points
- ◇ Logistic regression
- ◇ Figures of Merit
- ◇ Models optimization
- ◇ Decision trees basics
- ◇ Neural networks basics
- ◇ Neural Networks heuristics
- ◇ Illustrations
- ◇ Concluding remarks

Outlook

- ◇ Models and data
 - ◇ fundamental and Generic Models
 - ◇ types of Generic Models
- ◇ Formal set of the ML problem
- ◇ Practical points
- ◇ Logistic regression
- ◇ Figures of Merit
- ◇ Models optimization
- ◇ Neural networks basics
- ◇ Neural Networks heuristics
- ◇ Decision Trees
- ◇ Illustrations
- ◇ Concluding remarks

Fundamental Models

- ◇ Paradigm: **model first, then data**
- ◇ Some specific dependency is assumed *a priori* (e.g. a Nature law)
 - ◇ “fit parabola to data”
- ◇ Number of degrees of freedom corresponds to the problem (Occam razor)
 - ◇ smaller dimensions
 - ◇ faster and more stable converging
- ◇ Models are extendable beyond the domain of train parameters
- ◇ Interpretable representation
- ◇ Can not accommodate difference between parametric model and actual data

Example: Archery

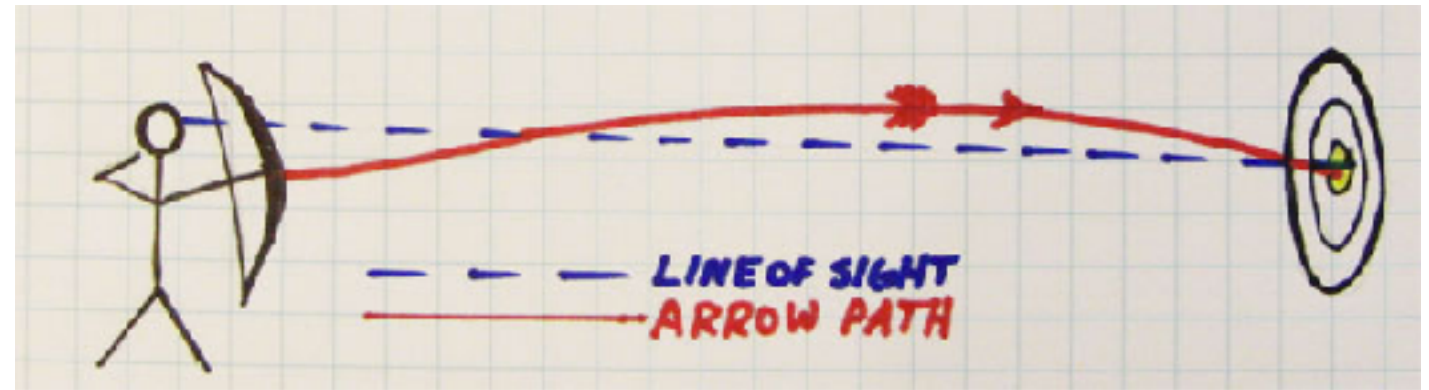

- ◇ A complicated interplay of gravity, aerodynamics, arrow oscillations etc.
- ◇ Should good archer be a good scientist?
 - ◇ absolutely not
- ◇ Can we build a good model from first principles?
 - ◇ hardly
- ◇ It is all about practice and experience

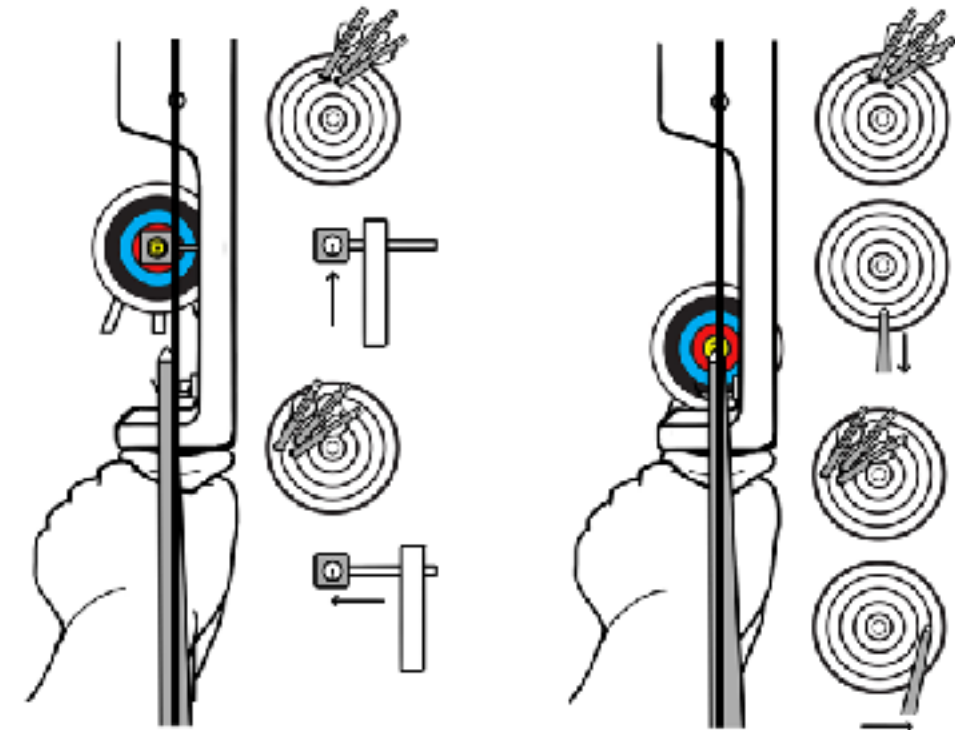

Illustrated by © Jessica Emswiler - www.illustration.com
This image can be used for personal and non-commercial use with credit. This image is a basic guide; always consult a qualified archery instructor.

Generic Models

- ◇ Paradigm: **data first, then model**
 - ◇ assumes nothing about dependency *a priori*
 - ◇ “find reasonable representation for data”
 - ◇ model \equiv data
 - ◇ universal - can accommodate most actual data
 - ◇ significantly over-defined problem
 - ◇ special regularisations are needed
 - ◇ less stable converging
 - ◇ significant computing resources needed
 - ◇ many speed up tricks are developed
 - ◇ extrapolation can not be trusted at all
 - ◇ hard to interpret
- ◇ Machine Learning is all about Generic Models

Types of Learning

- ◇ There is a set of well labelled data
 - ◇ we want to learn how to produce labels for more data like this
 - ◇ this is automation of some routine
 - ◇ **supervised learning**
- ◇ There is a set of labelled data, and unlabelled data which are assumed to be similar
 - ◇ we want to derive labels
 - ◇ this is propagation of knowledge
 - ◇ still **supervised learning**
- ◇ There is a set of unlabelled data with some properties
 - ◇ we want to infer properties of this data
 - ◇ this is inferring new knowledge
 - ◇ **unsupervised learning**

Machine Learning Pipeline

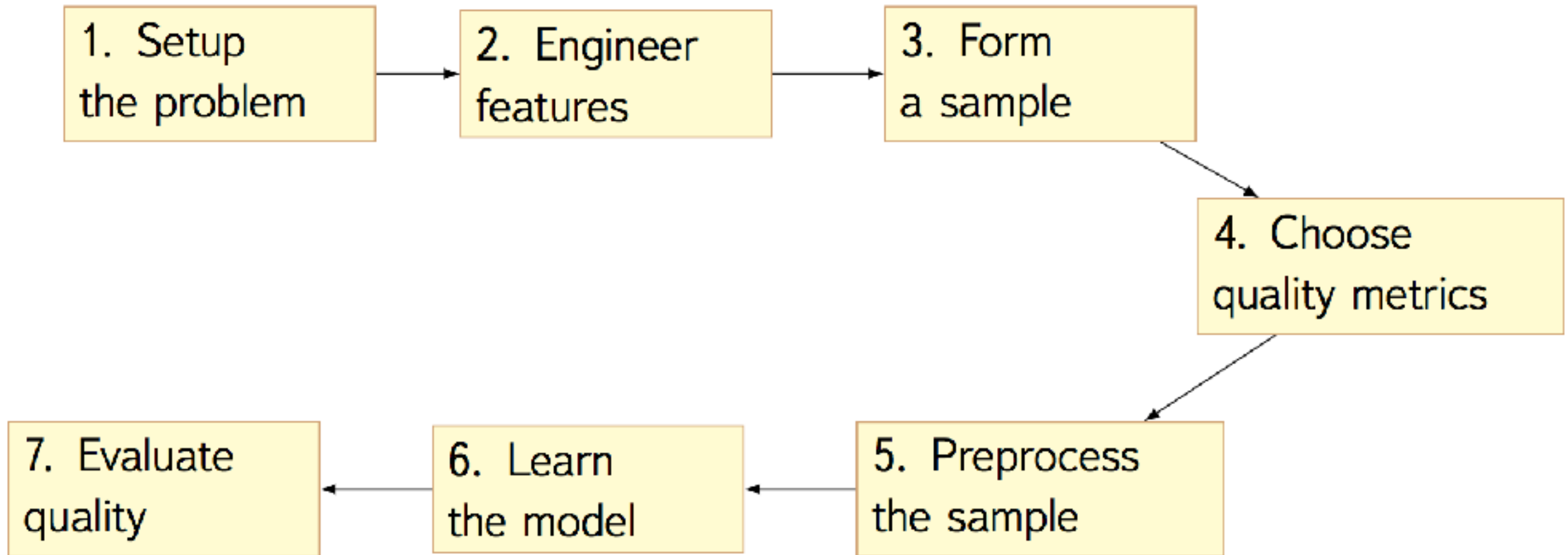

Machine Learning Pipeline

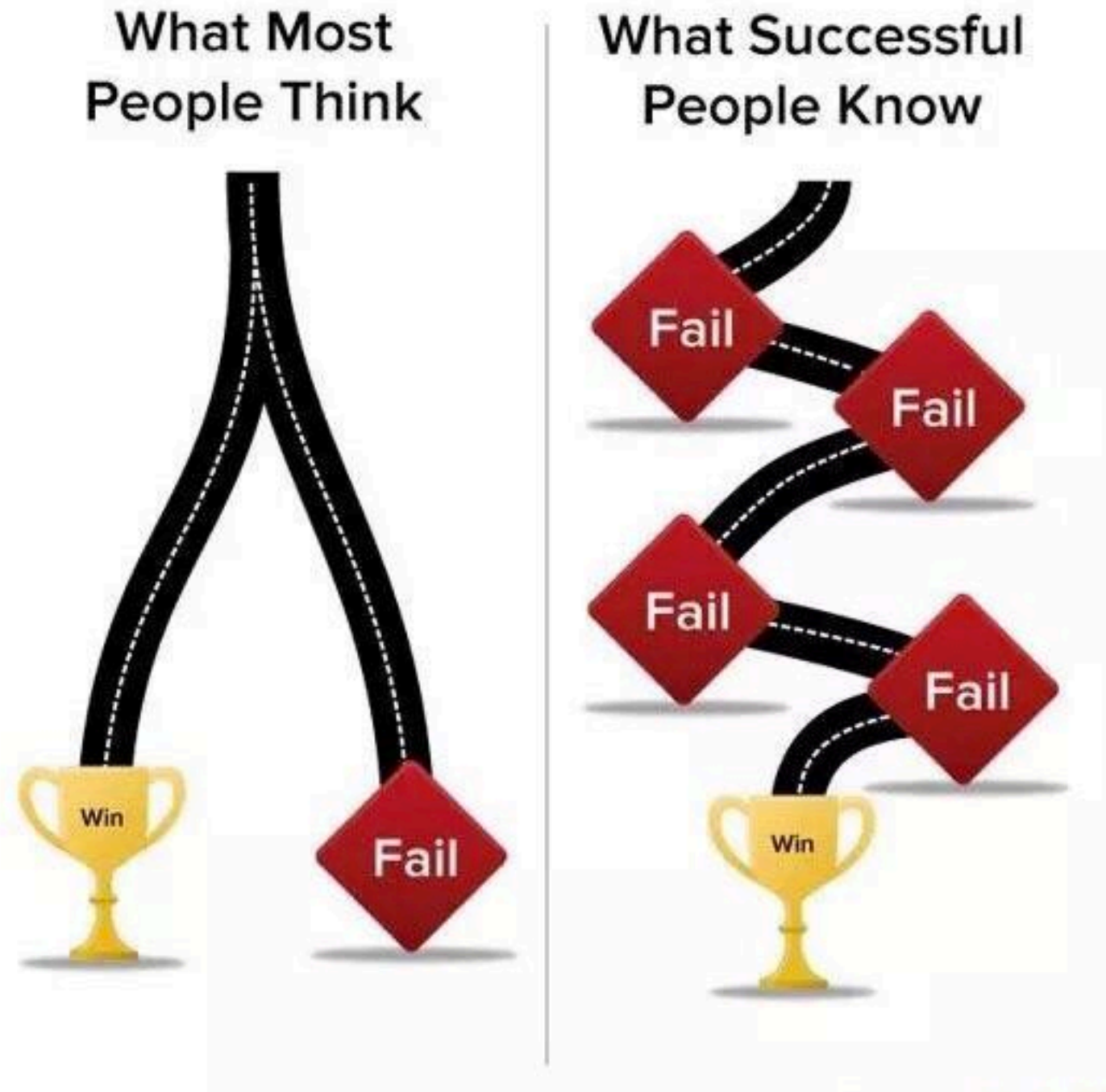

Machine Learning Pipeline

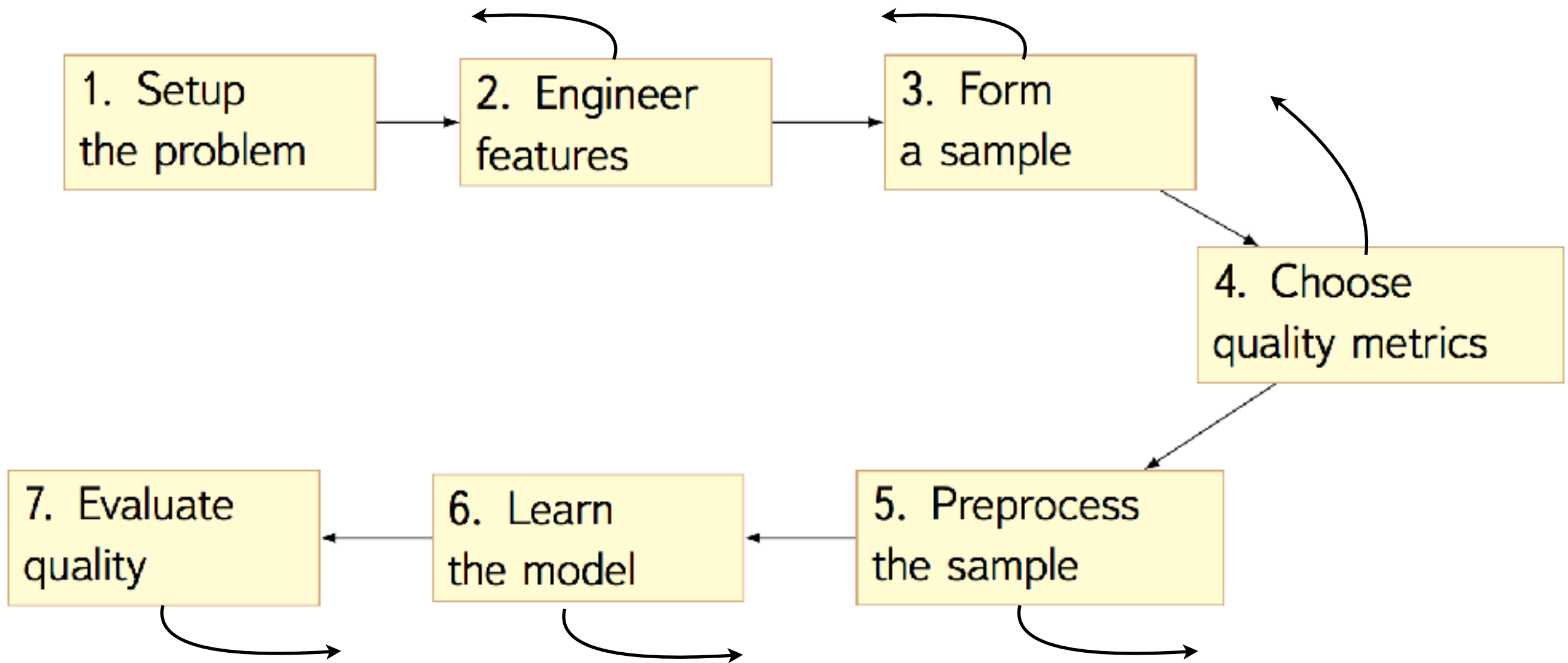

Outlook

- ◇ Models and data
- ◇ Formal set of the ML problem
 - ◇ main concepts and definitions
 - ◇ KNN classification example
- ◇ Practical points
- ◇ Logistic regression
- ◇ Figures of Merit
- ◇ Models optimization
- ◇ Neural networks basics
- ◇ Neural Networks heuristics
- ◇ Decision Trees
- ◇ Illustrations
- ◇ Concluding remarks

Basic Problem of the Supervised Learning

X - set of objects

Y - set of answers

$y : X \rightarrow Y$ - unknown dependency

Given:

$\{x_1, x_2, \dots, x_k\} \subset X$ - *training sample*

$\{y_1, y_2, \dots, y_k\} \subset Y$ - answers for objects in training sample

Target:

find $a : X \rightarrow Y$ - *decision function* approximating y on the full dataset X

Machine Learning is all about:

- what are possible objects and answers?
- what is the meaning of “ a approximates y ”?
- how to build function a ?

Object Features

Objects of X are completely defined by set of features:

$f_j : X \rightarrow D_j$ $j=1, 2, \dots, n$ - object *features*

$D_j = \{0, 1\}$ - *binary feature*

e.g. {"charged", "neutral"} for particles

$D_j = \{c_1, c_2, \dots, c_l\}$ - *categorical feature*

e.g. {"electron", "muon", "pion", "kaon", "proton"}

$D_j = \mathbb{R}$ - *numeric feature*

e.g. subatomic particle momentum

MC particle: $f : x \rightarrow \{PDGid, p_x, p_y, p_z, v_x, v_y, v_z\}$ $n=7$

Types of the Supervised ML Problems

Classification:

$Y = \{-1, +1\}$ - two-class classification

e.g. “signal”, “background”

$Y = \{1, 2, \dots, M\}$ - multi-class classification

e.g. particle ID

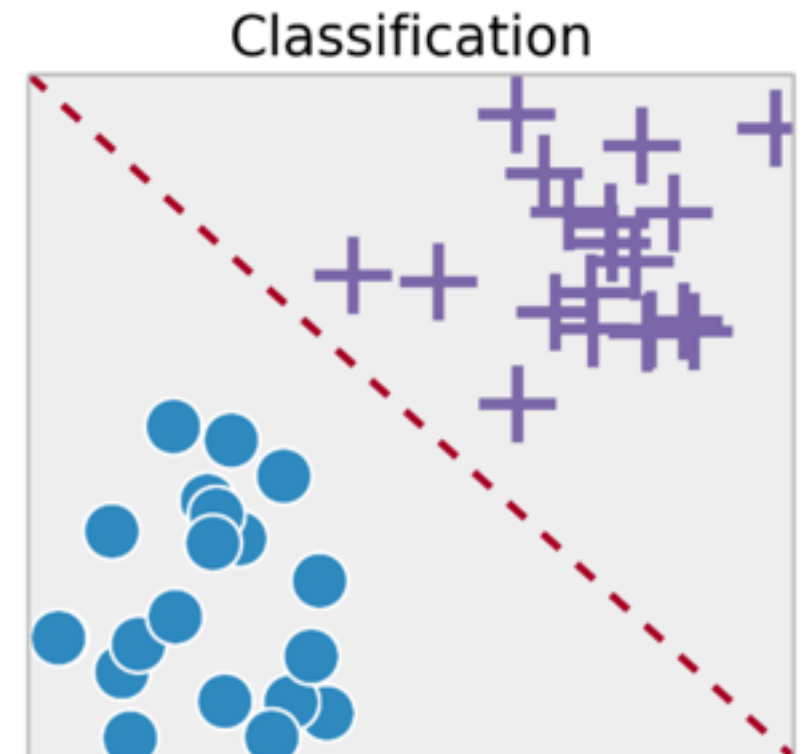

Regression:

$Y = \mathbb{R}$ or $Y = \mathbb{R}^m$

e.g. reconstructed subatomic particle kinematics

grey area:

classification may be in terms of probabilities

regression may be in terms of e.g. integers

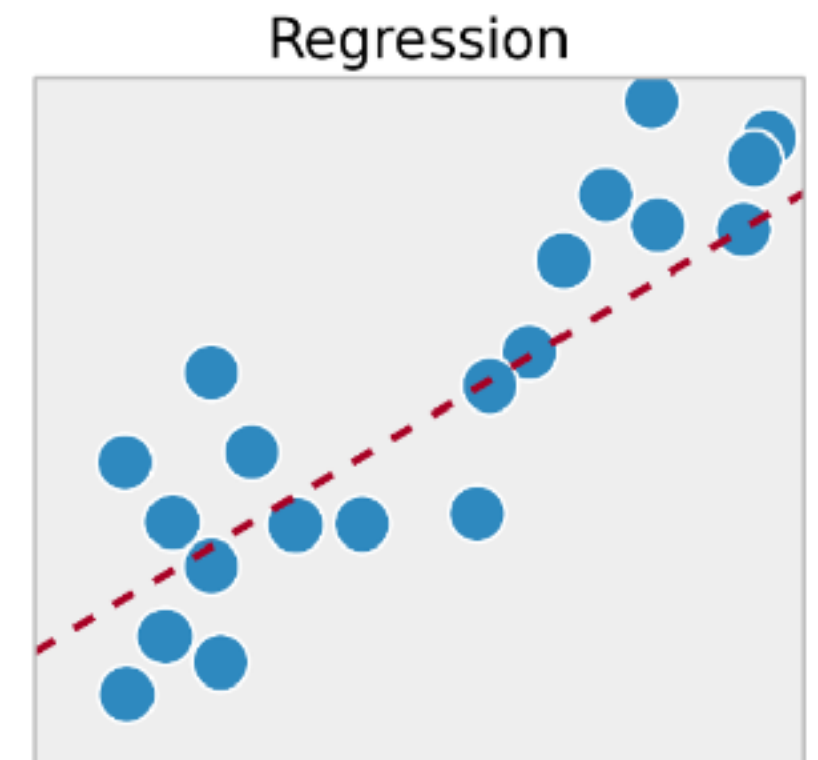

Iris Flowers Dataset (Fisher, 1936)

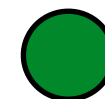
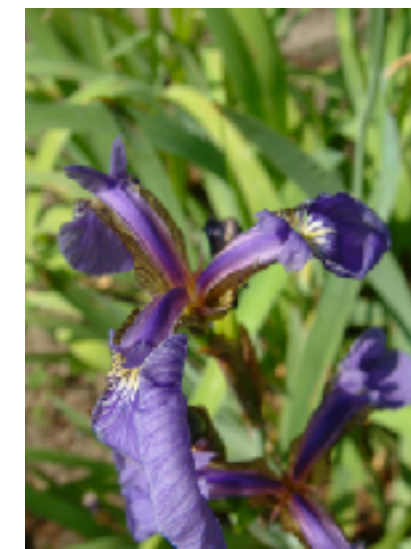
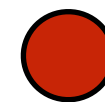
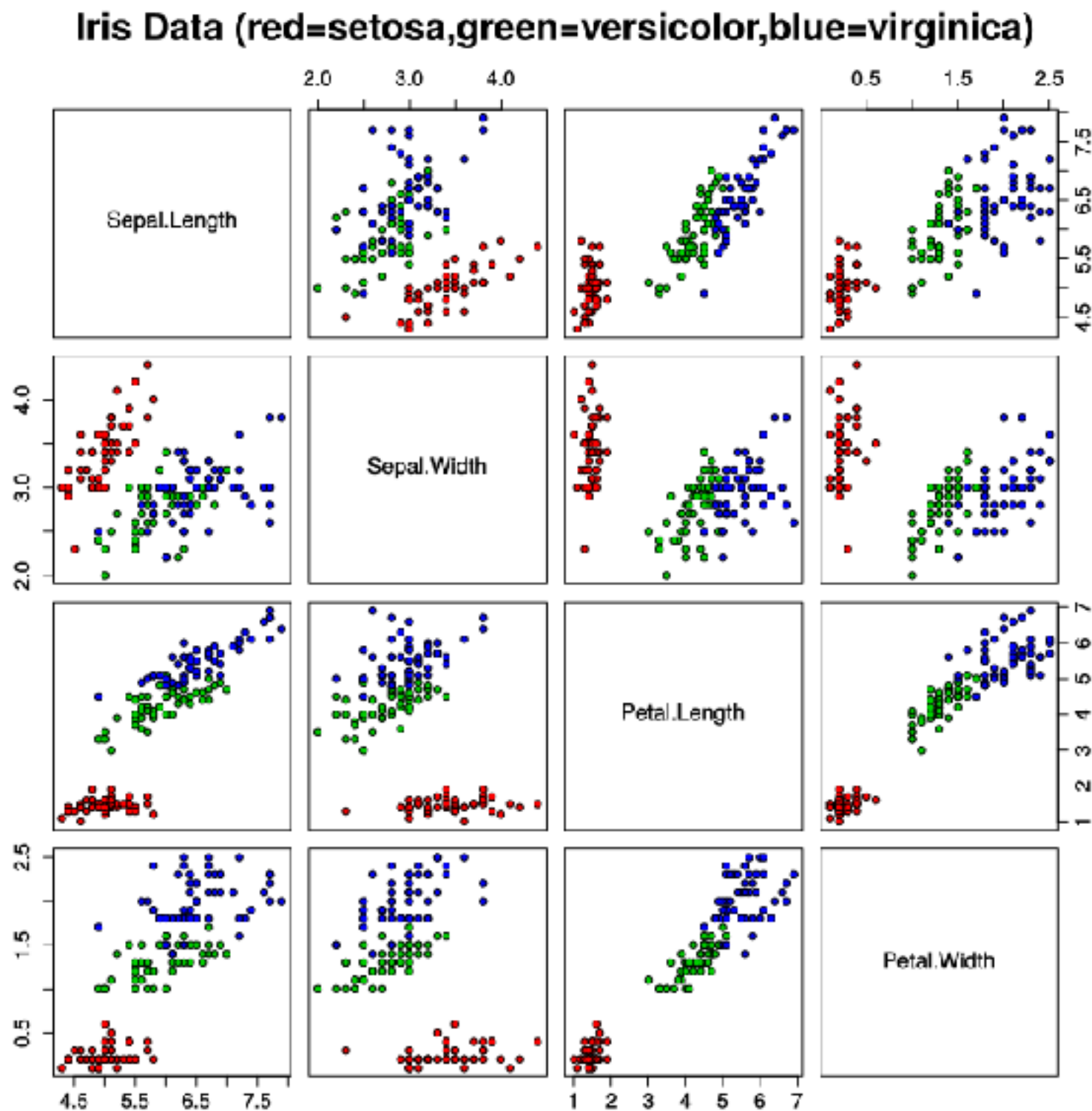

4 features, 3 classes, 150 objects

Predictive Model

$$A = \{g(x, \theta) \mid \theta \in \Theta\}$$

where:

$g: X \times \Theta \rightarrow Y$ - well defined function

Θ - set of possible values for parameter θ

e.g. linear model with parameter vector $\theta = (\theta_1, \dots, \theta_n)$, $\Theta = \mathbb{R}^n$

$$g(x, \theta) = \sum_{j=1}^n \theta_j f_j(x) \quad \text{- regression}$$

$$g(x, \theta) = \text{sign} \sum_{j=1}^n \theta_j f_j(x) \quad \text{- classification}$$

Features May Be Different

Regression, $X = Y = \mathbb{R}$, 3 features: $\{x, x^2, 1\}$ or $\{x, \sin(x), 1\}$

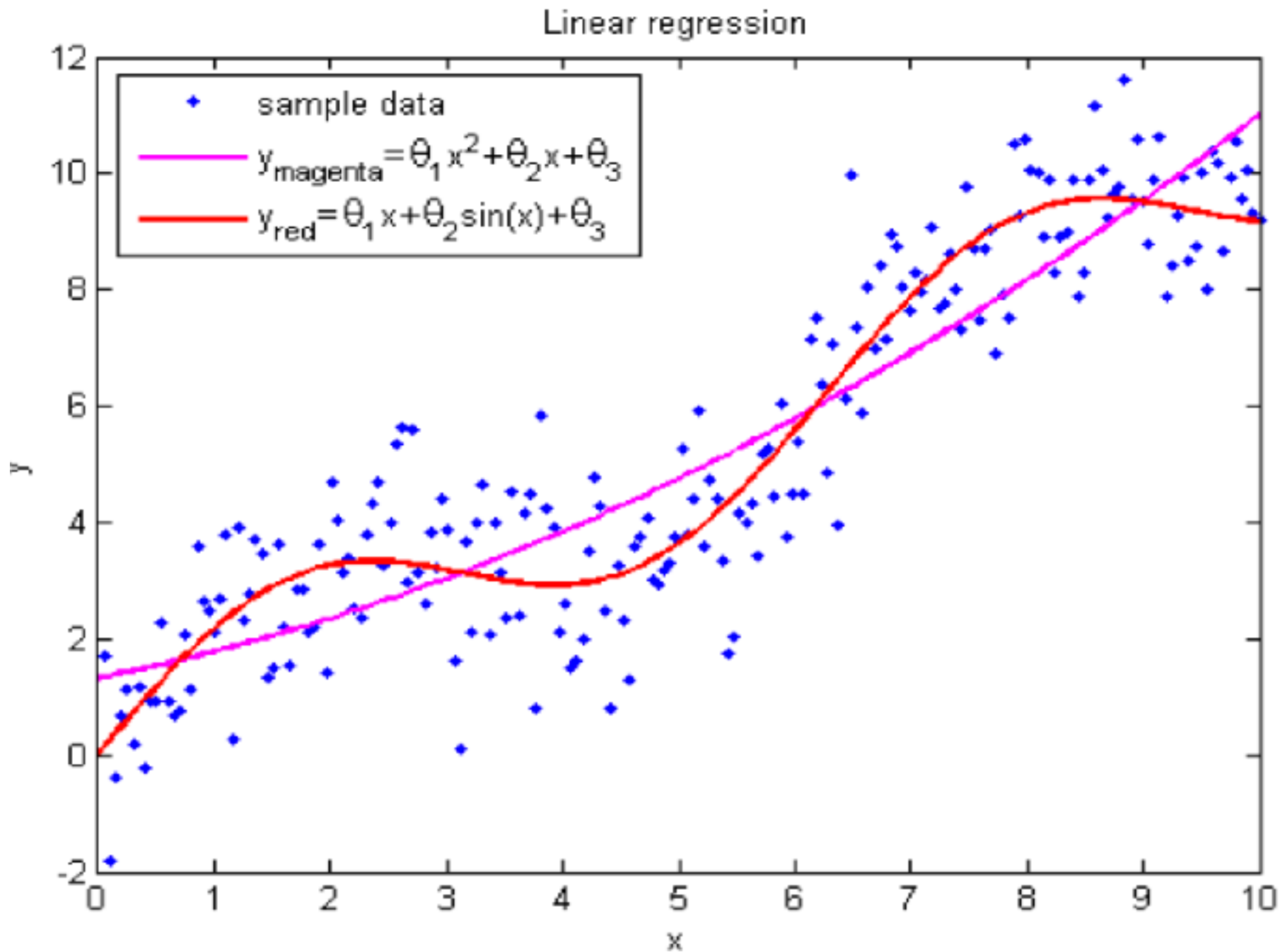

Features May Be Different

Regression, $X = Y = \mathbb{R}$, 3 features: $\{x, x^2, 1\}$ or $\{x, \sin(x), 1\}$

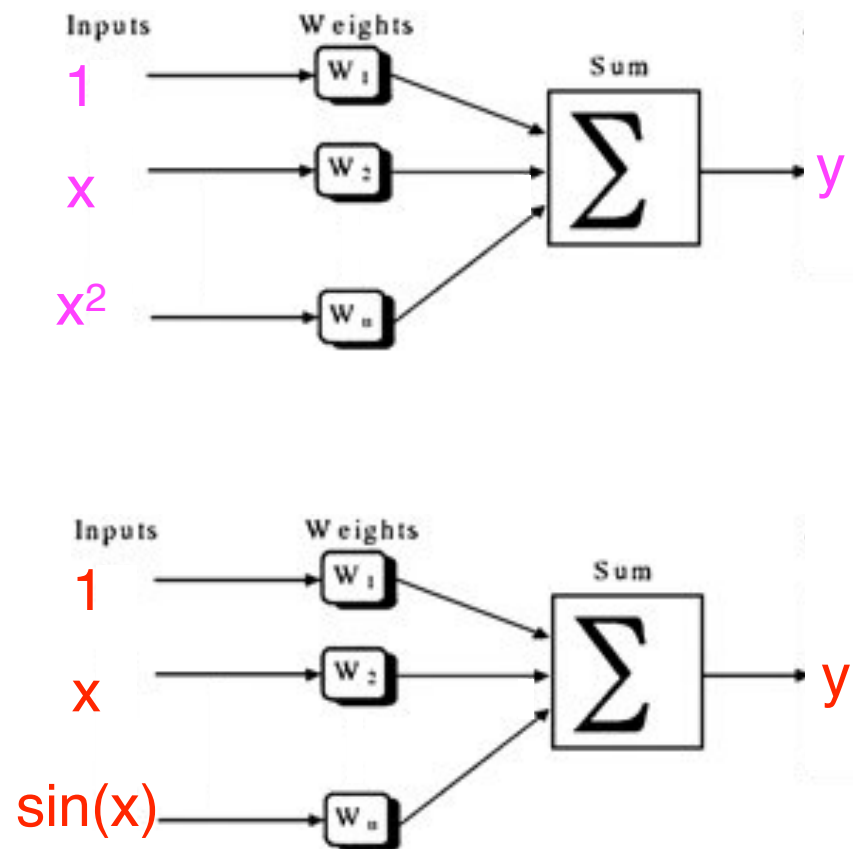
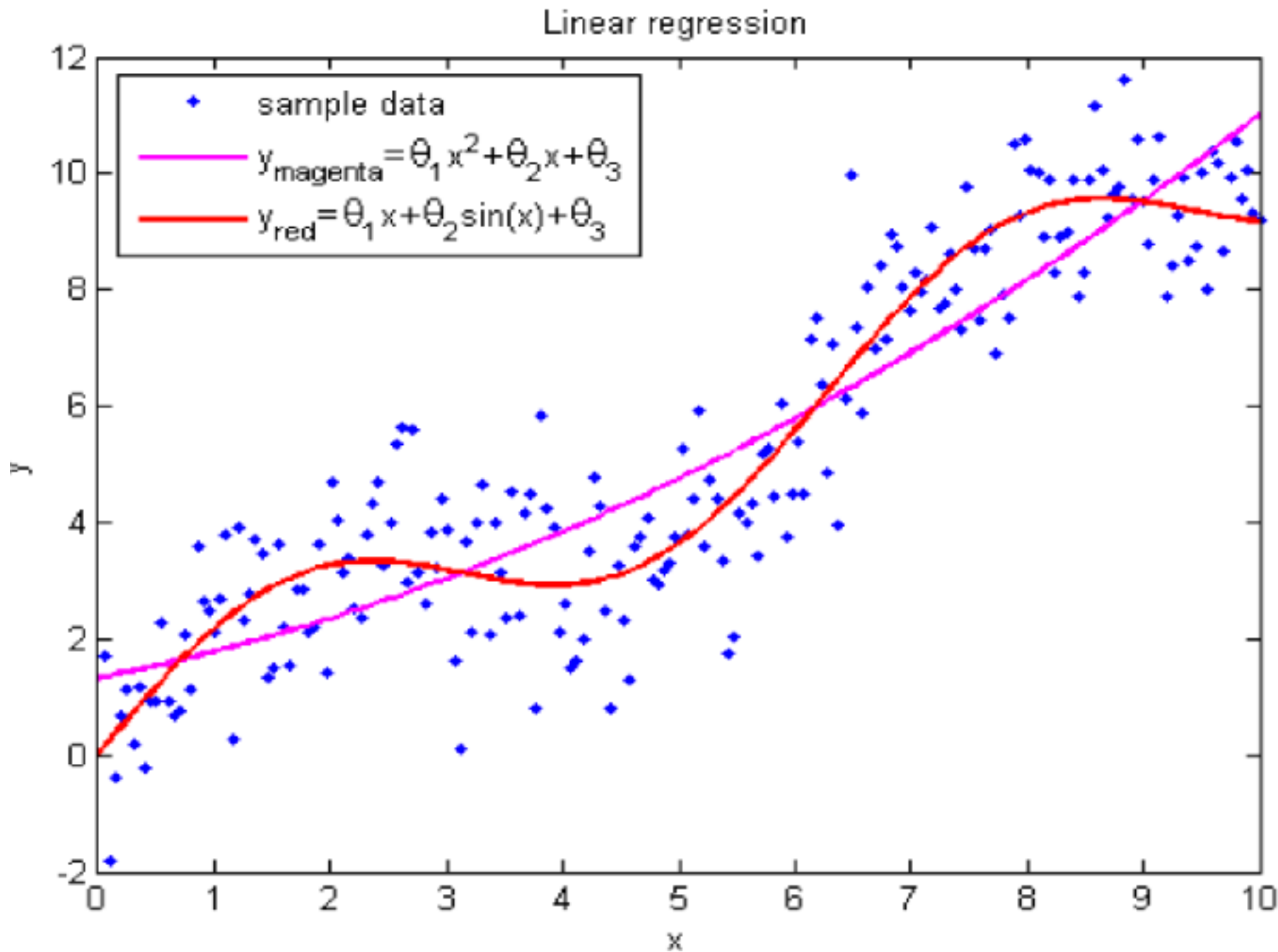

Learning Algorithm

learning algorithm μ is a function to convert a particular data sample into predictive model:

$$\mu : \{(x_i, y_i)\}_{i=1..l} \rightarrow a \in A \qquad A = \{g(x, \theta) \mid \theta \in \Theta\}$$

Two stages for the supervised learning

training: μ builds a using train set $\{(x_i, y_i)\}_{i=1..l}$

testing: a predicts y for $x \in X$

Train and Test

1: build a

$$\begin{pmatrix} f_1(x_1) & \dots & f_n(x_1) \\ \dots & \dots & \dots \\ f_1(x_\ell) & \dots & f_n(x_\ell) \end{pmatrix} \xrightarrow{y} \begin{pmatrix} y_1 \\ \dots \\ y_\ell \end{pmatrix} \xrightarrow{\mu} a$$

2: test a

$$\begin{pmatrix} f_1(x'_1) & \dots & f_n(x'_1) \\ \dots & \dots & \dots \\ f_1(x'_k) & \dots & f_n(x'_k) \end{pmatrix} \xrightarrow{a} \begin{pmatrix} a(x'_1) \\ \dots \\ a(x'_k) \end{pmatrix}$$

Loss Function

What is the meaning of “**a approximates y**”?

loss function: $\mathcal{L}(x,a)$ — prediction error of algorithm $a \in A$ on the object $x \in X$

classification:

$$\mathcal{L}(x,a) = [a(x) \neq y(x)] \text{ — error indicator}$$

regression:

$$\mathcal{L}(x,a) = |a(x) - y(x)| \text{ — absolute error}$$

$$\mathcal{L}(x,a) = (a(x) - y(x))^2 \text{ — quadratic error}$$

...

empirical risk: mean loss on the data sample X^ℓ :

$$Q(a, X^\ell) = \frac{1}{\ell} \sum_{i=1}^{\ell} \mathcal{L}(a, x_i).$$

Nearest Neighbour Classification

we have a train sample $X = \{x_i, y_i\}, i=1..l$

there is a distance $\rho(x', x'')$ defined in space of features

for any x algorithm predicts $y = y_i, i = \arg \min \rho(x, x_i)$

algorithm: search in train dataset, no training *per se*

2-class Classification With 2 Features

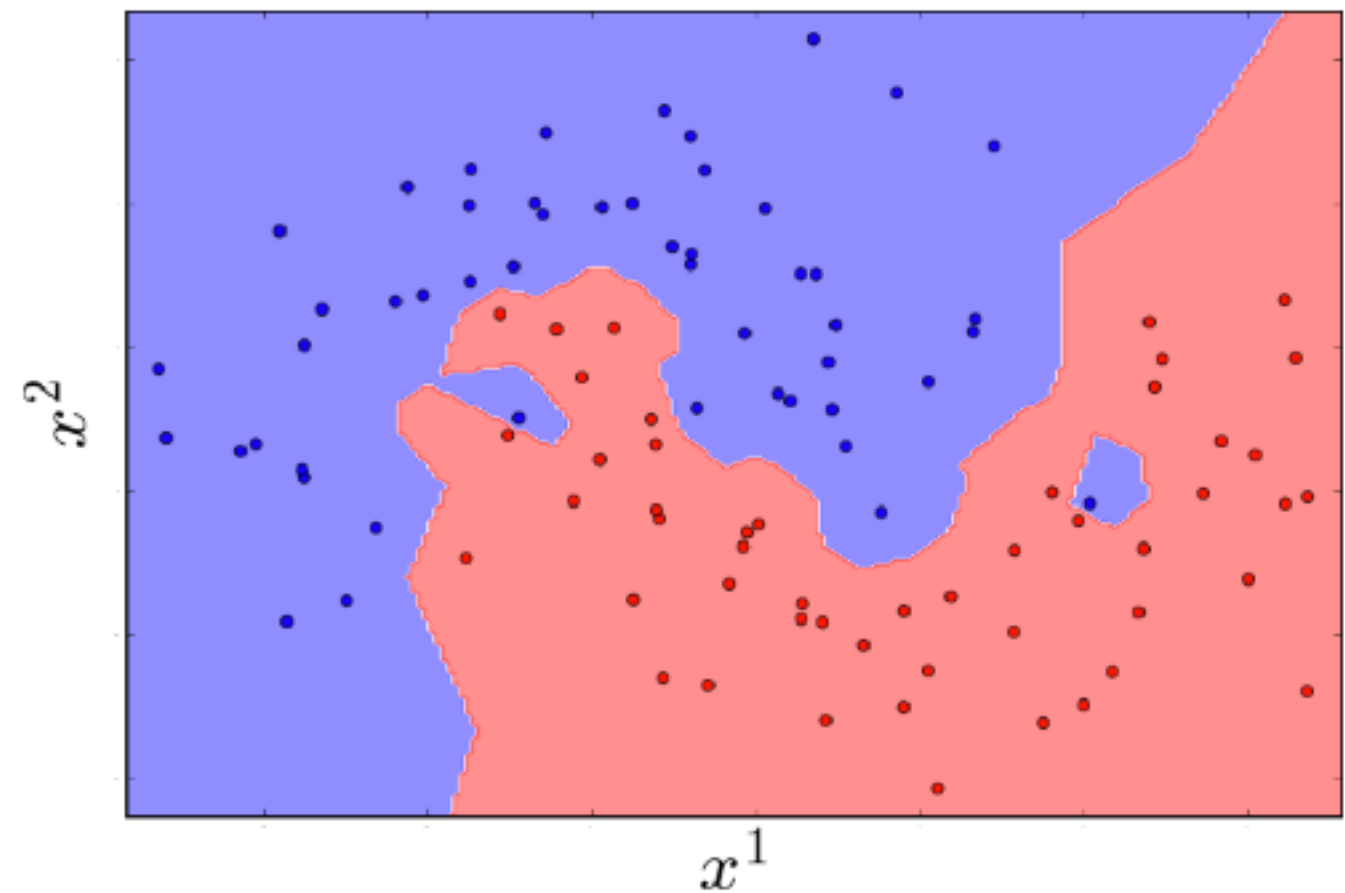
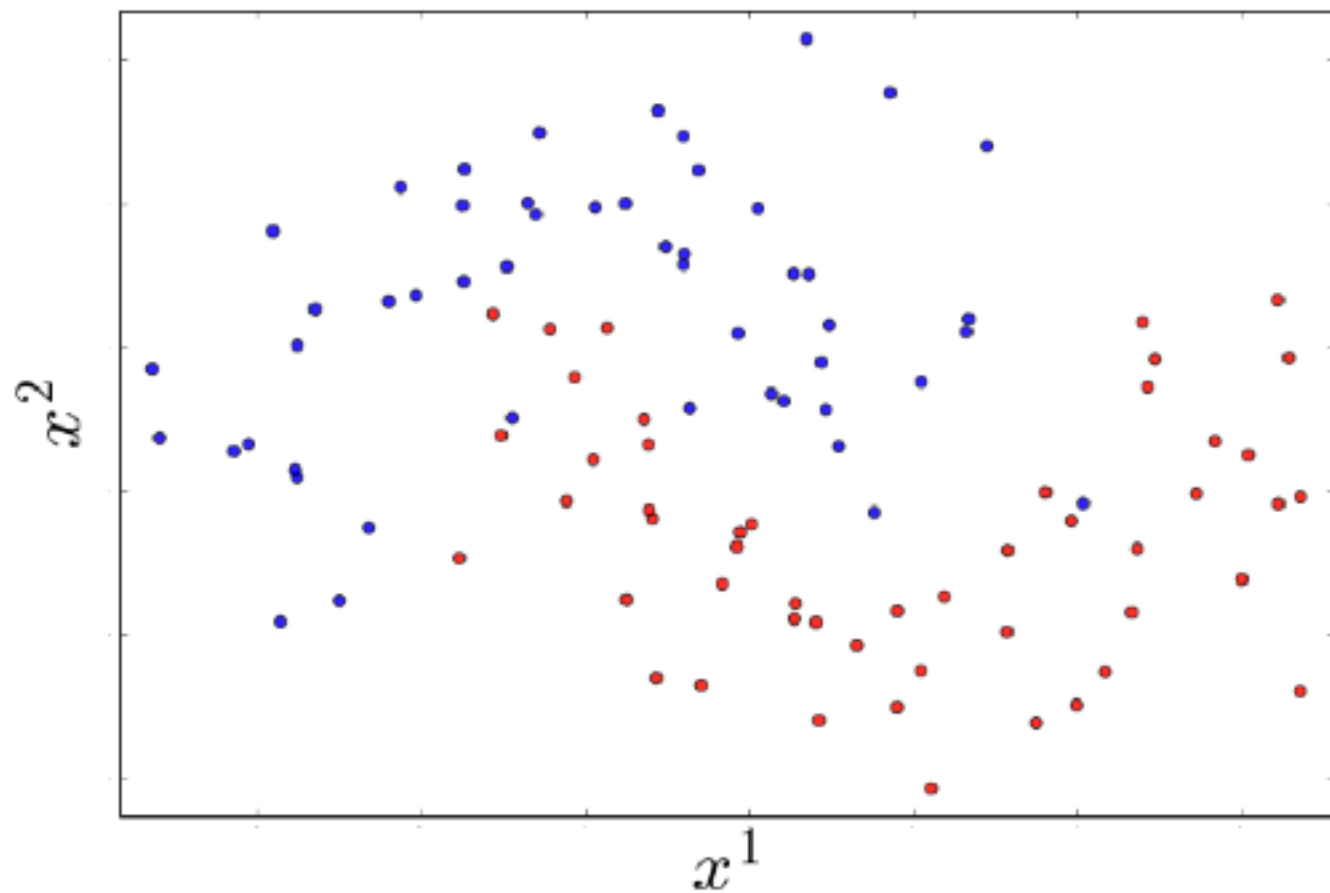

k Nearest Neighbours (kNN)

using k neighbours improves stability

$$p(x) = \# (\text{kNN events in } X \text{ of class } \{1\}) / k$$

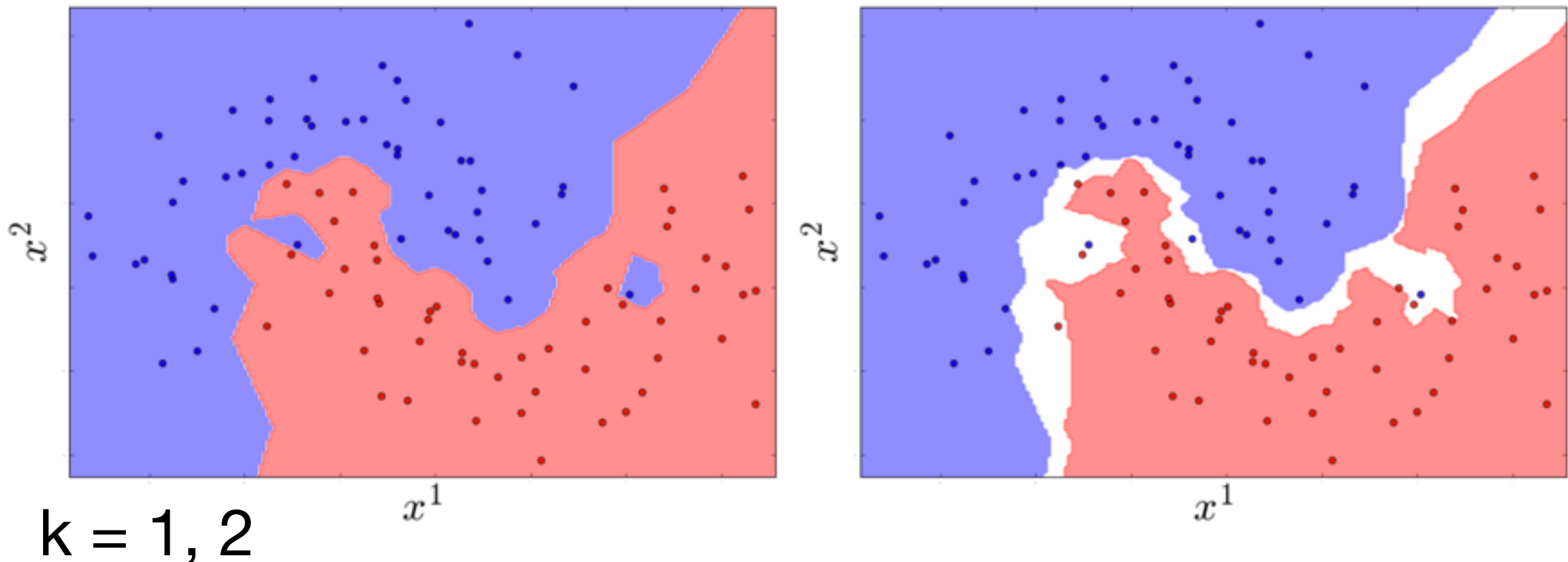

k Nearest Neighbours (kNN)

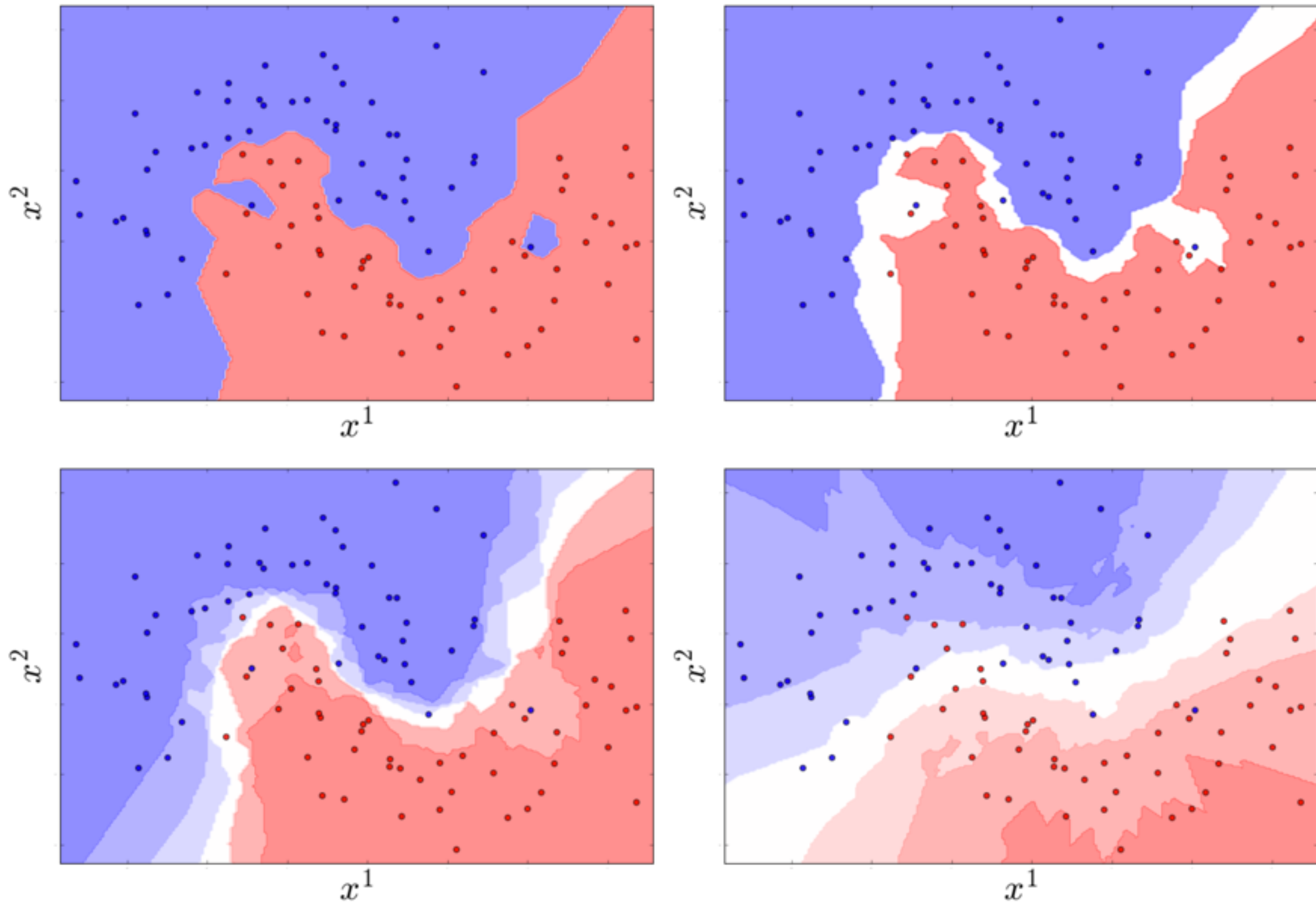

$k = 1, 2, 5, 30$

Overfitting

What is the quality of classification on training dataset with $k=1$?

answer: it is ideal (closest neighbour is the event itself)

quality is lower when $k>1$

however this doesn't mean $k=1$ is the best

it means we **cannot use training events to estimate quality**

when classifier's decision rule is too complex it captures details from training data that are not relevant to distribution

we call this an overfitting (more on this later)

Outlook

- ◇ Models and data
- ◇ Formal set of the ML problem
- ◇ **Practical points**
 - ◇ optimization
 - ◇ overfitting
 - ◇ regularization
- ◇ Logistic regression
- ◇ Figures of Merit
- ◇ Models optimization
- ◇ Decision Trees
- ◇ Neural networks basics
- ◇ Neural Networks heuristics
- ◇ Illustrations
- ◇ Concluding remarks

Supervised Learning IS Optimization

empirical risk:

$$Q(a, X^\ell) = \frac{1}{\ell} \sum_{i=1}^{\ell} \mathcal{L}(a, x_i).$$

learning algorithm:

$$\mu(X^\ell) = \arg \min_{a \in A} Q(a, X^\ell)$$

e.g. least squares method:

$$\mu(X^\ell) = \arg \min_{\theta} \sum_{i=1}^{\ell} (g(x_i, \theta) - y_i)^2$$

How Generic is Result?

$$\mu(X^\ell) = \arg \min_{\theta} \sum_{i=1}^{\ell} (g(x_i, \theta) - y_i)^2$$

- is $g(x, \theta)$ generic for all $x \in X$, or is it tuned for train set X^l ?
- will $Q(a, X^k)$ keep being small on different, test subset of X ?

Overtraining problem

Illustration

consider function:

$$y(x) = \frac{1}{1 + 25x^2} \quad x \in [-2, 2].$$

features — powers of x :

$$x \mapsto (1, x^1, x^2, \dots, x^n)$$

linear regression:

$$a(x, \theta) = \theta_0 + \theta_1 x + \dots$$

use least squares learning algorithm:

$$Q(\theta, X^\ell) = \sum_{i=1}^{\ell} (\theta_0 + \theta_1 x_i + \dots + \theta_n x_i^n - y_i)^2 \rightarrow \min_{\theta_0, \dots, \theta_n}.$$

train sample:

$$X^\ell = \left\{ x_i = 4 \frac{i-1}{\ell-1} - 2 \mid i = 1, \dots, \ell \right\}$$

test sample:

$$X^k = \left\{ x_i = 4 \frac{i-0.5}{\ell-1} - 2 \mid i = 1, \dots, \ell - 1 \right\}$$

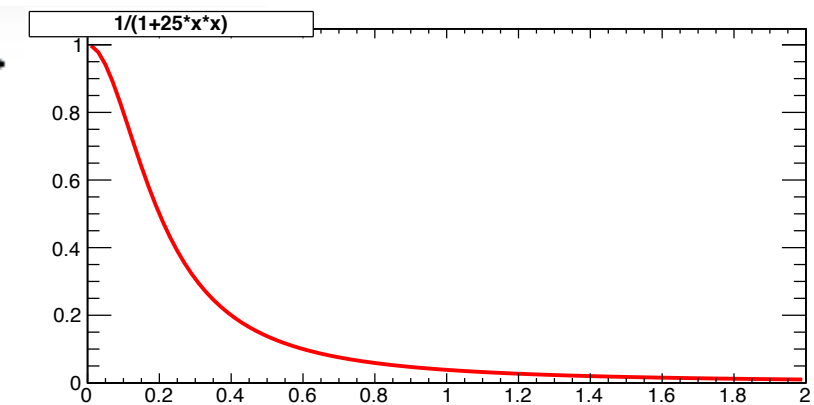

How Q behaves as n increases?

Empirical Risks (n=1..31)

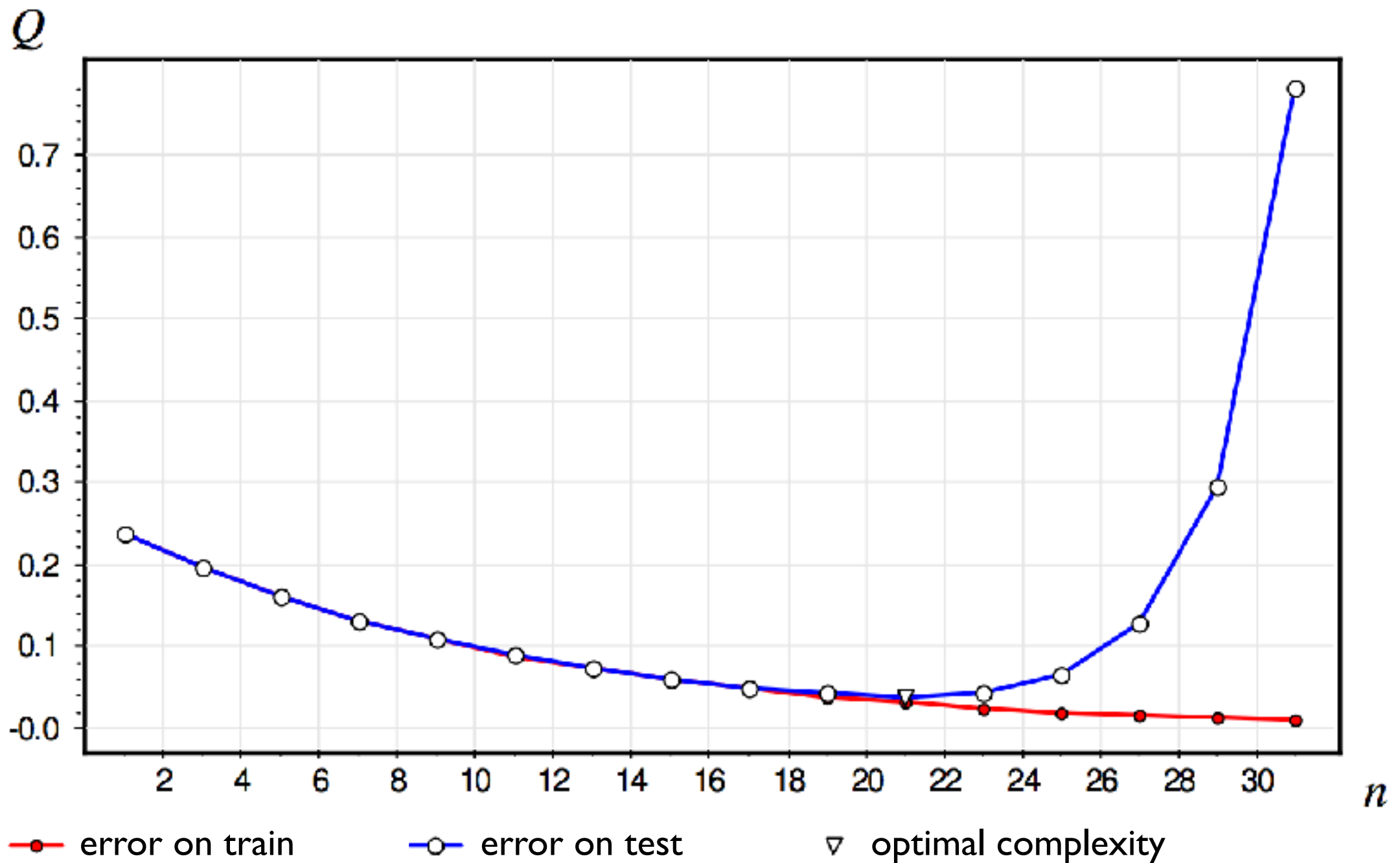

overtraining (overfitting): $Q(\mu(X^l), X^k) \gg Q(\mu(X^l), X^l)$

$$a(x) = P_{38}(x)$$

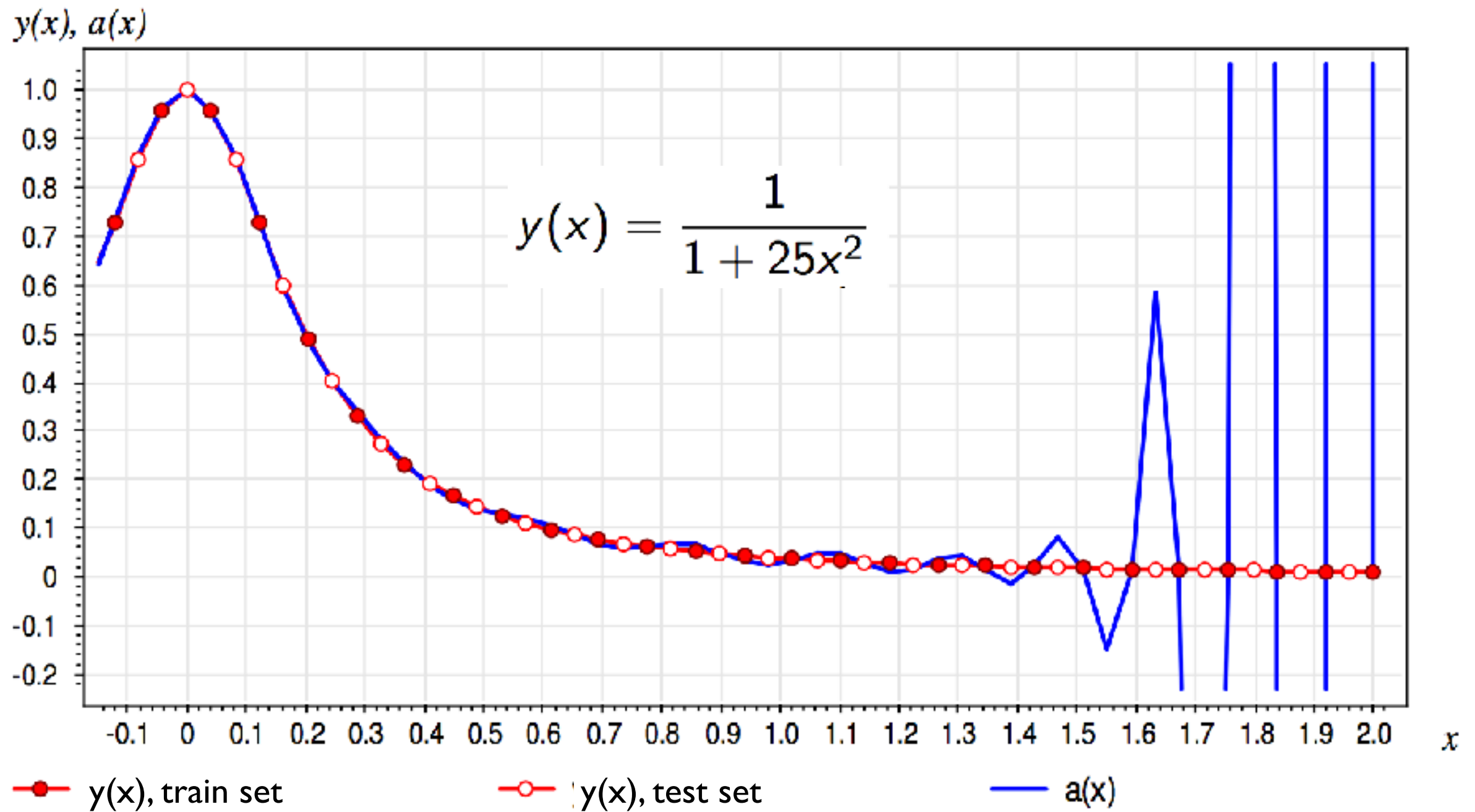

Numerical Optimization

Consider optimization problem:

$$f(\mathbf{x}) \rightarrow \min_{\mathbf{x} \in \mathbb{R}^d} \quad (\text{such as } \sum_{i=1}^{\ell} \left(y_i - \sum_{k=1}^d w_k x_{ki} \right)^2 \rightarrow \min_{w \in \mathbb{R}^d})$$

Usually solved by **gradient descent** method

$$\nabla_{\mathbf{x}} f(\mathbf{x}) \equiv \left(\frac{\partial f(\mathbf{x})}{\partial x_1}, \dots, \frac{\partial f(\mathbf{x})}{\partial x_d} \right)$$

$$\mathbf{x}^{(k)} \leftarrow \mathbf{x}^{(k-1)} - \alpha_k \nabla_{\mathbf{x}} f(\mathbf{x}^{(k-1)})$$

converges as $f(\mathbf{x}^{(k)}) - f(\mathbf{x}^*) = \mathcal{O}(1/k)$

$0 < \alpha_k < 1$ — **learning rate**

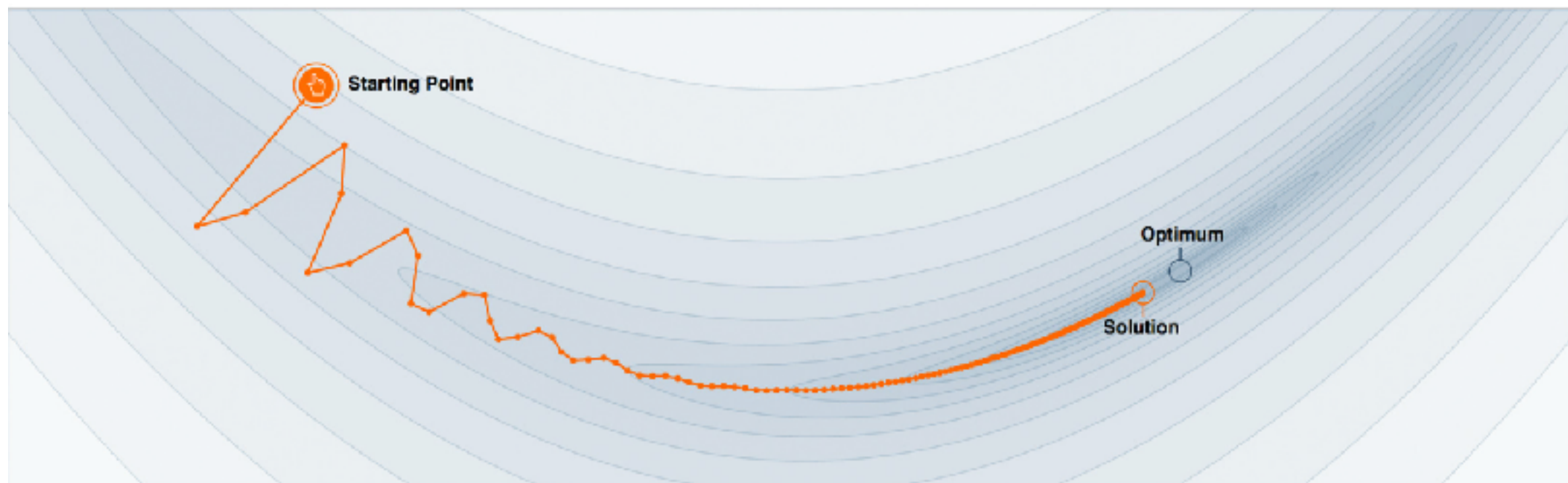
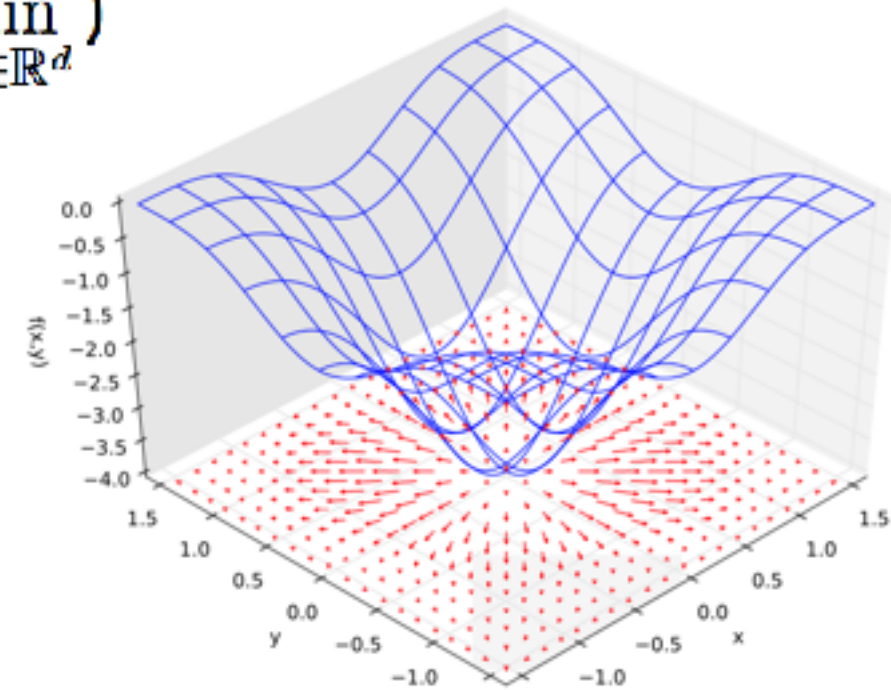

Stochastic Gradient Descent

ML approaches usually use empirical risk function which is a sum of losses over train dataset:

$$f(\mathbf{w}) = \sum_{i=1}^{\ell} f_i(\mathbf{w})$$

computationally heavy for $\ell \gg 1$

trick: on each iteration randomly pick one $1 \leq i_k \leq \ell$ and step in that direction:

$$\mathbf{w}^{(k)} \leftarrow \mathbf{w}^{(k-1)} - \alpha_k \nabla_{\mathbf{w}} f_{i_k}(\mathbf{w}^{(k-1)})$$

converges as $f(\mathbf{w}^{(k)}) - f(\mathbf{w}^*) = \mathcal{O}(1/\sqrt{k})$

batches, momentum and other tricks may improve converging rates

Gradient Descent vs Stochastic Gradient Descent

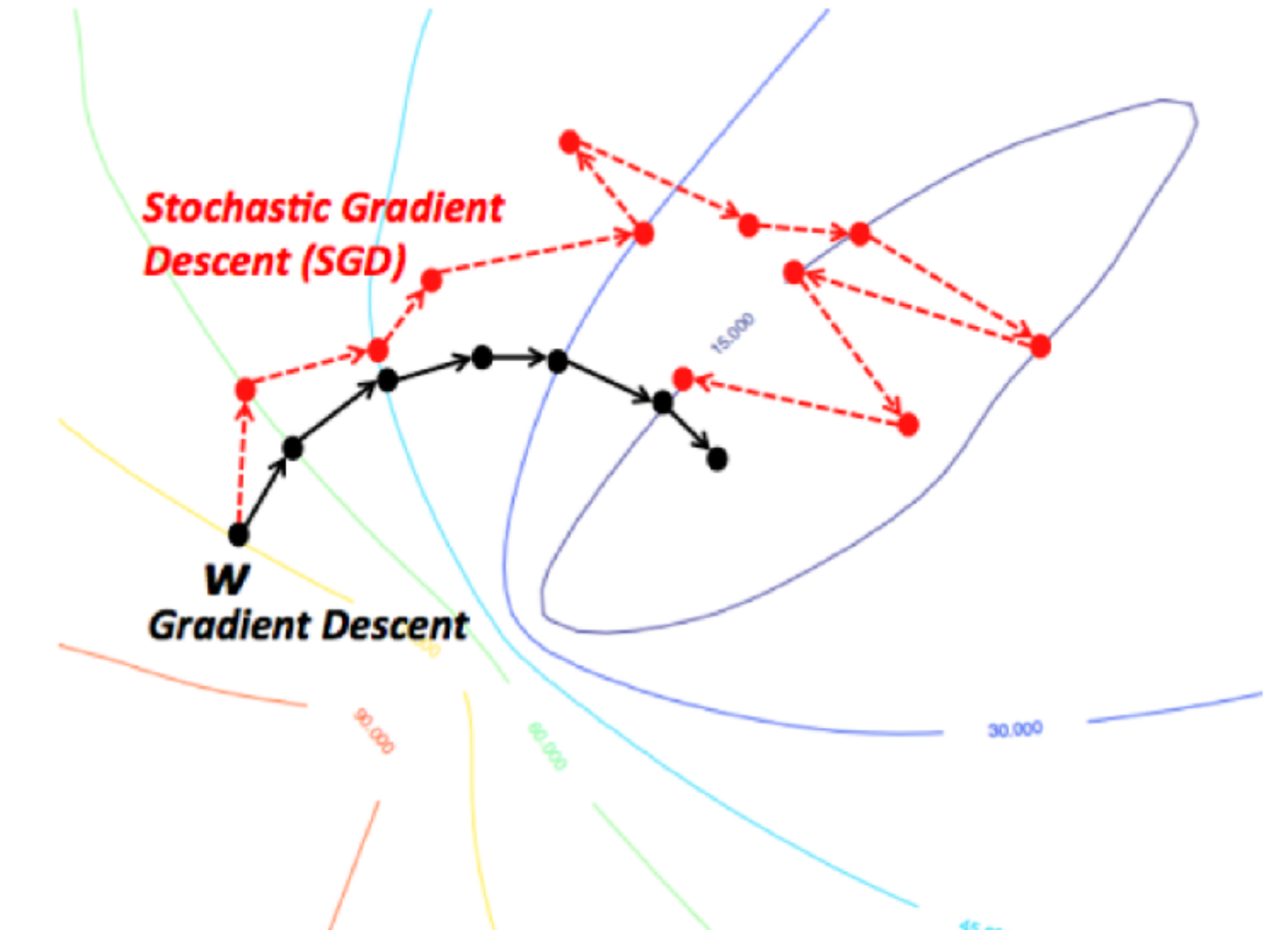

SDG With Momentum

$$\Delta \mathbf{w}^{(k)} = -\alpha \nabla_{\mathbf{w}} f_i(\mathbf{w}^{(k-1)})$$

$$\mathbf{w}^{(k)} = \mathbf{w}^{(k-1)} + \Delta \mathbf{w}^{(k)}$$



$$\Delta \mathbf{w}^{(k)} = \gamma \Delta \mathbf{w}^{(k-1)} - \alpha \nabla_{\mathbf{w}} f_i(\mathbf{w}^{(k-1)})$$

$$\mathbf{w}^{(k)} = \mathbf{w}^{(k-1)} + \Delta \mathbf{w}^{(k)}$$



and many other approaches with adaptive learning rate

Various Optimizers Illustration

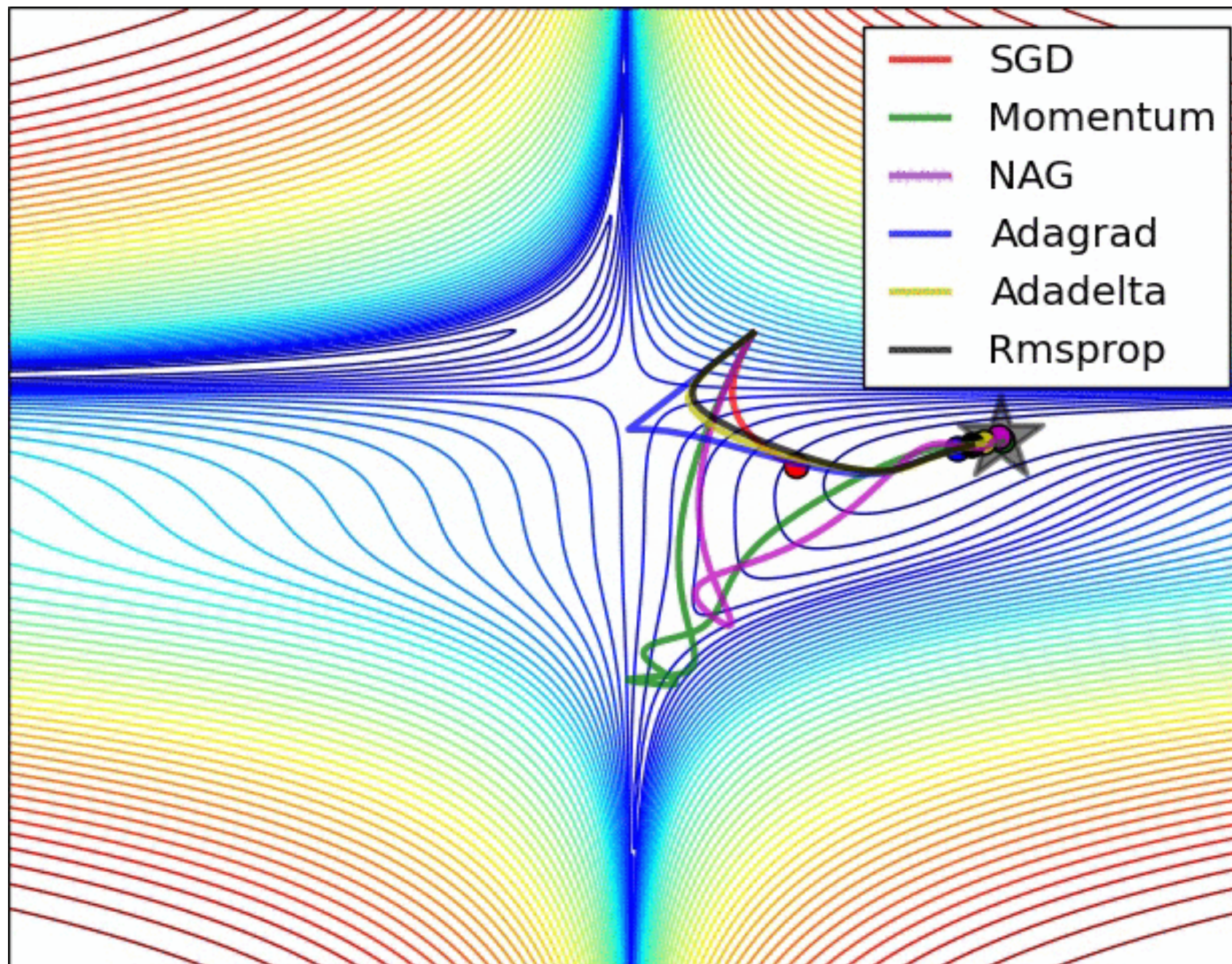

<https://imgur.com/a/Hqolp>

adaptive learning rate and momentum helps

Regularization

generic models usually use more parameters than actual dimensions of the function

under-defined optimization problem →
collinear features → multidimensional
optimum valleys → computational problems

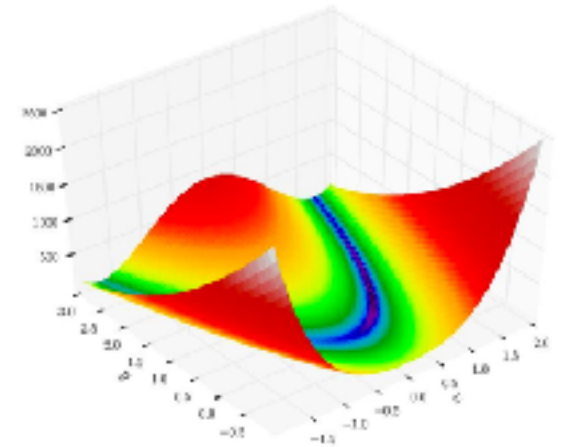

fit → fit + penalty for large values —
regularization:

$$Q(\mathbf{w}) \rightarrow Q_\alpha(\mathbf{w}) = Q(\mathbf{w}) + \alpha R(\mathbf{w})$$

$R(\mathbf{w})$ — regularizer,

α — regularization constant

Regularization Types

L2 regularization:

$$R(\mathbf{w}) = \sum w_i^2$$

L1 (LASSO) regularization:

$$R(\mathbf{w}) = \sum |w_i|$$

L1/L2 regularization (Elastic Net)

$$\alpha \sum w_i^2 + \beta \sum |w_i|$$

Geometric Interpretation

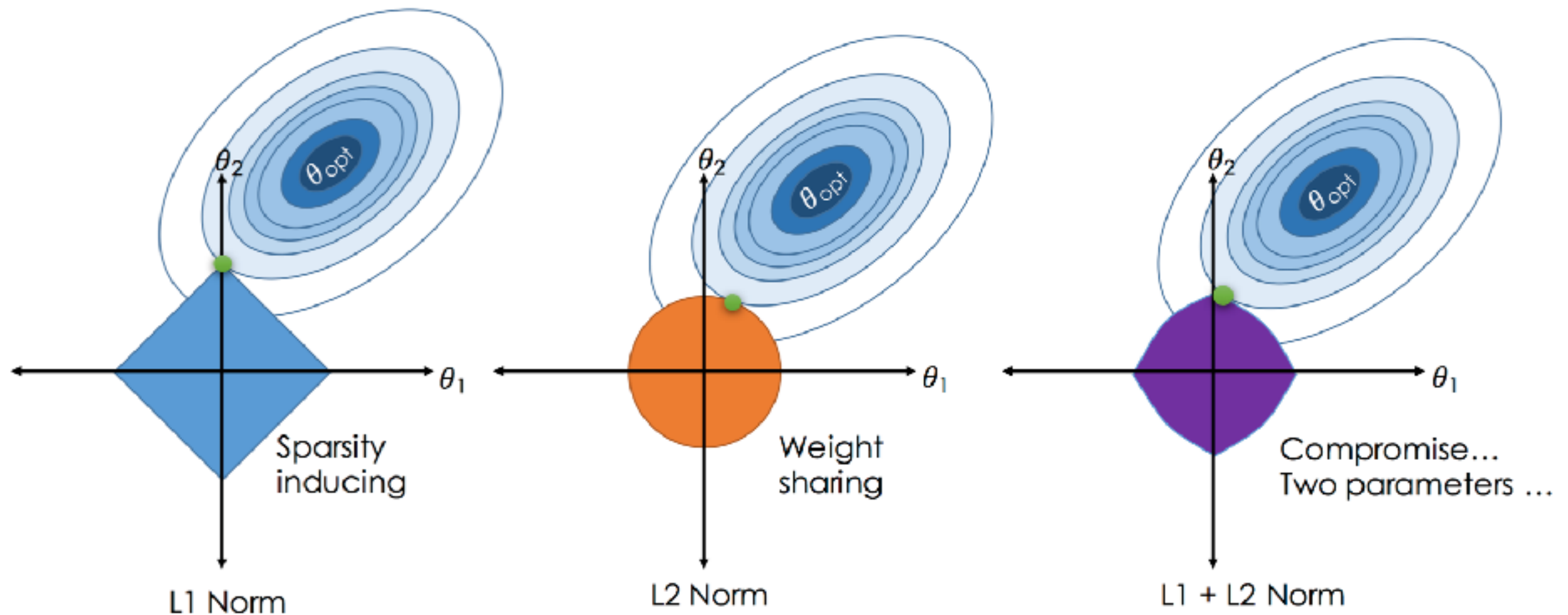

Picture credit: http://www.ds100.org/sp17/assets/notebooks/linear_regression/Regularization.html

Another Interpretation



Figure: Large parameter space



Figure: Regularized models

End of the Lecture I

Outlook

- ◇ Models and data
- ◇ Formal set of the ML problem
- ◇ Practical points
- ◇ **Logistic regression**
- ◇ Figures of Merit
- ◇ Models optimization
- ◇ Decision Trees
- ◇ Neural networks basics
- ◇ Neural Networks heuristics
- ◇ Illustrations
- ◇ Concluding remarks

Logistic Regression

We want to separate objects of two classes

Domains for classes essentially intersect

Probabilistic separation is appropriate in this case:

logistic regression

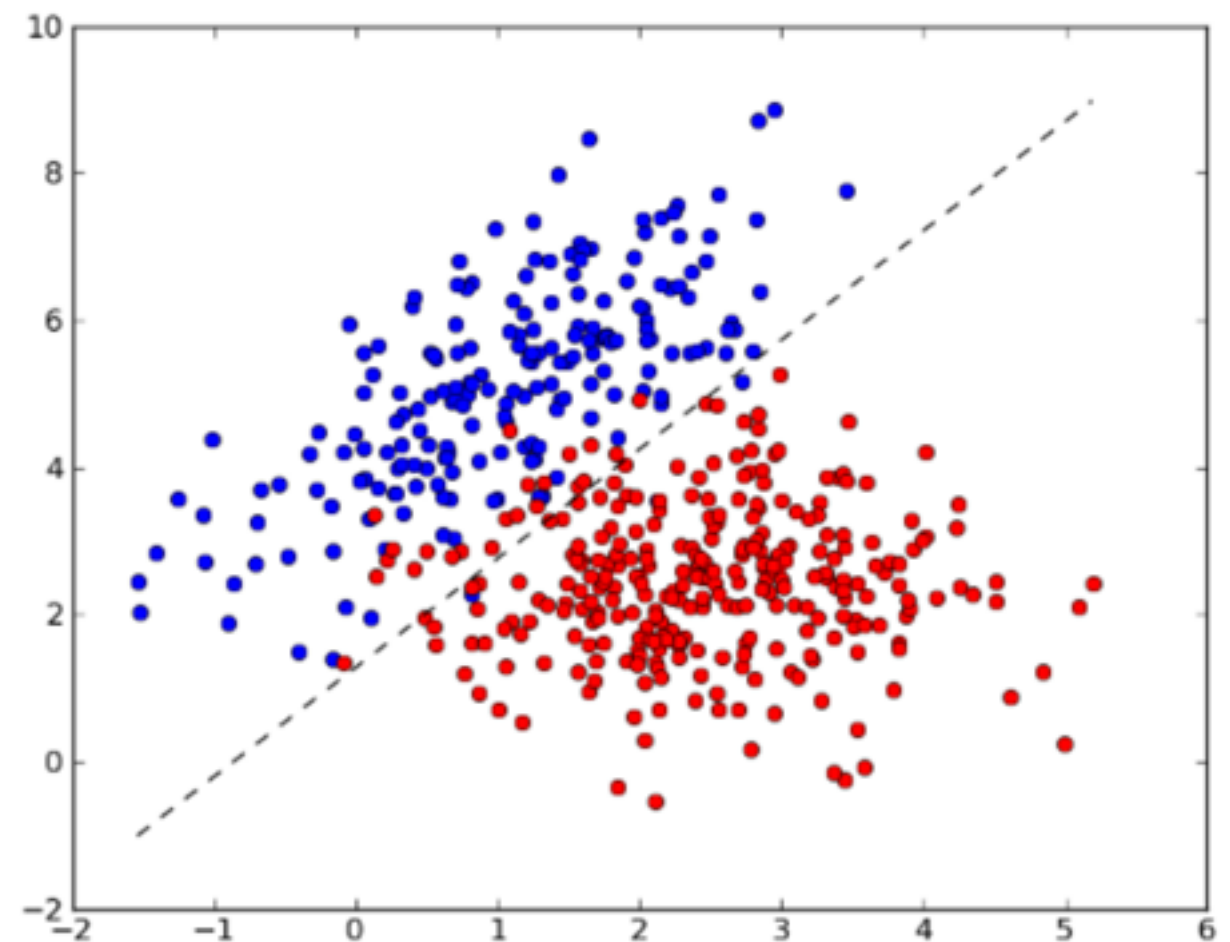
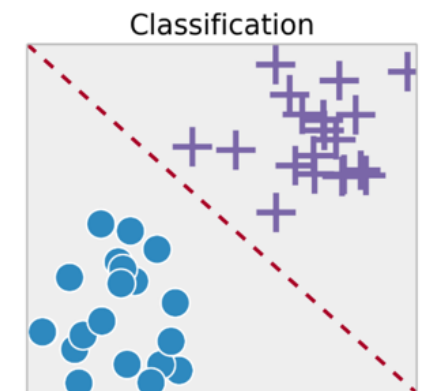

Logistic Regression Model

Training set $X^\ell = \{(\mathbf{x}_i, y_i)\}_{i=1}^\ell$ where $y_i \in \{-1, +1\}$

We seek an algorithm h such that $h(\mathbf{x}) = \mathbb{P}(y = +1|\mathbf{x})$ (model probability!)

A probability that an instance (\mathbf{x}_i, y_i) is encountered in X^ℓ

$$h(\mathbf{x}_i)^{[y_i=+1]} + (1 - h(\mathbf{x}_i))^{[y_i=-1]}$$

Entire X^ℓ likelihood:

$$L(X^\ell) = \prod_{i=1}^{\ell} h(\mathbf{x}_i)^{[y_i=+1]} + (1 - h(\mathbf{x}_i))^{[y_i=-1]}$$

is often written via **log-likelihood** (of which the negative is **log-loss**)

$$\log L(X^\ell) = \sum_{i=1}^{\ell} [y_i = +1] \log h(\mathbf{x}_i) + [y_i = -1] \log(1 - h(\mathbf{x}_i))$$

NB: classic classification decision boundary is set by $h(x) = 0.5$

Logistic Regression Model

The choice of h : sigmoid function

$$h(\mathbf{x}) = \sigma(\mathbf{w}^T \mathbf{x})$$

where $\sigma(x) \in [0, 1]$

Typical choice: the logistic function

$$\sigma(\mathbf{w}^T \mathbf{x}) = \frac{1}{1 + \exp(-\mathbf{w}^T \mathbf{x})}$$

Plugging the logistic function into the loss yields an approximation of accuracy

$$\sum_{i=1}^{\ell} (1 + \exp(\mathbf{w}^T \mathbf{x}_i)) \rightarrow \min_{\mathbf{w} \in \mathbb{R}^d}$$

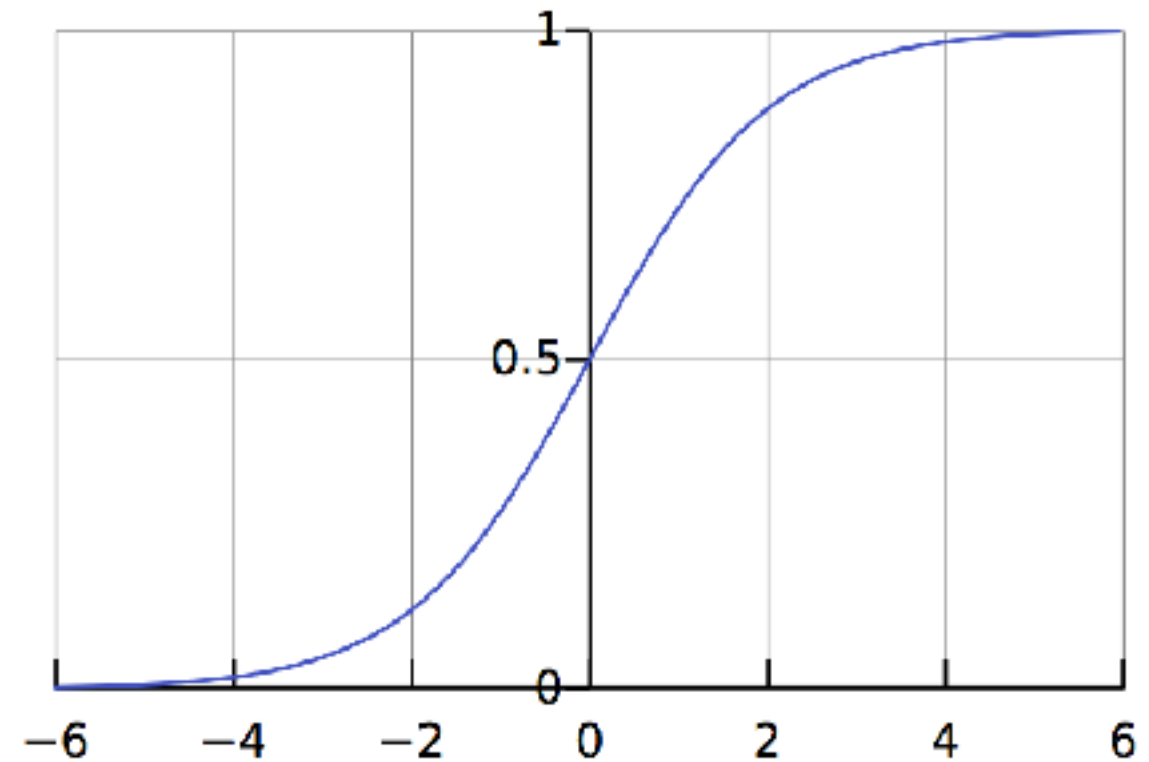
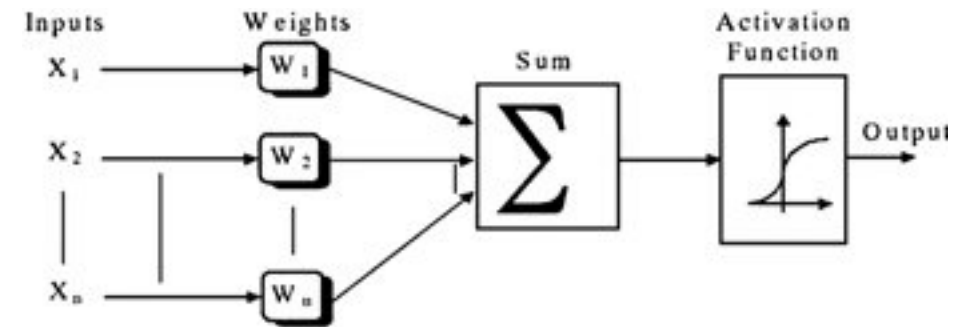

Logistic Regression Model

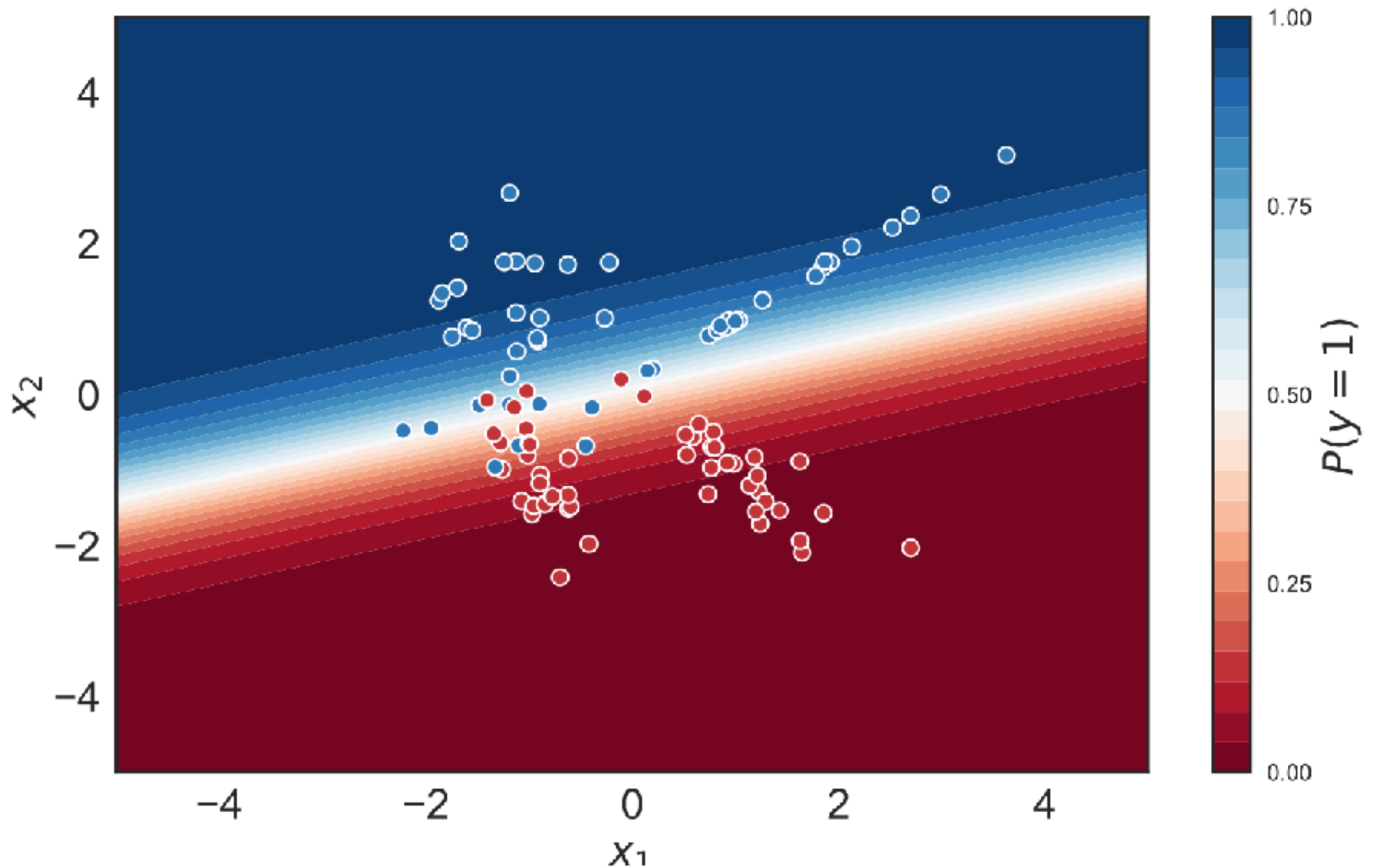

classic classification decision boundary is set by $h(x) = 0.5$

Is Linear Regression Too Restrictive?

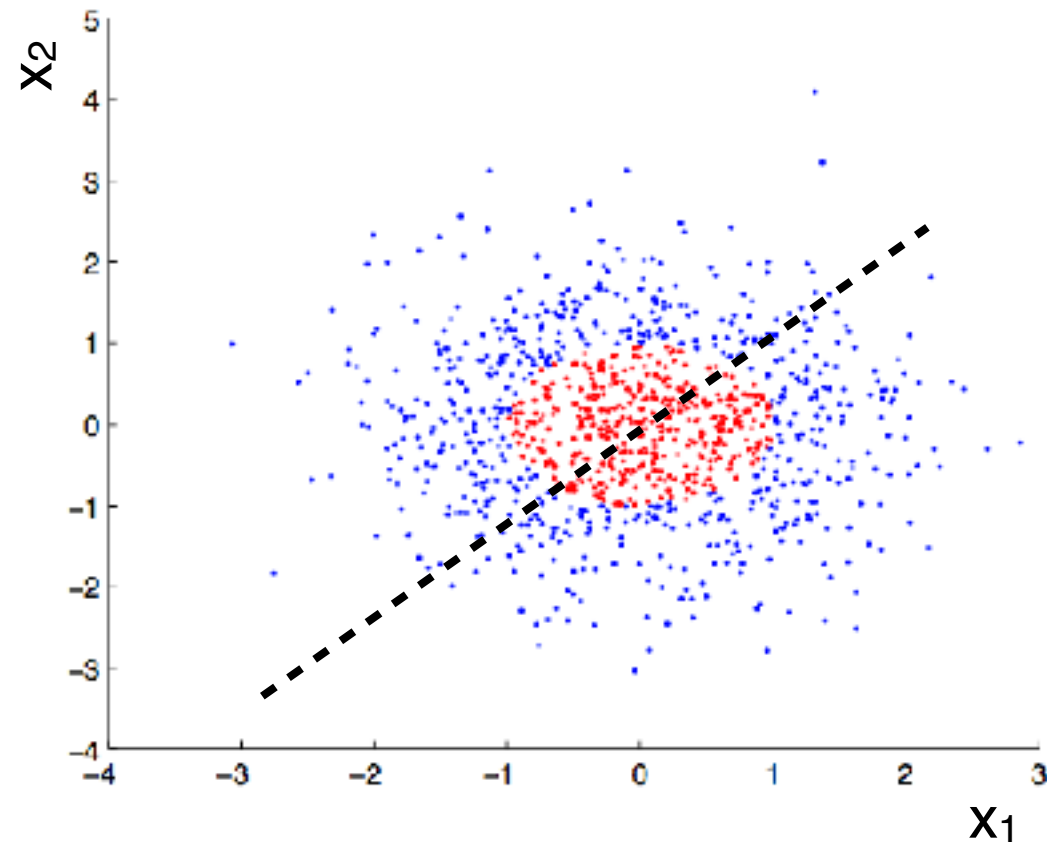
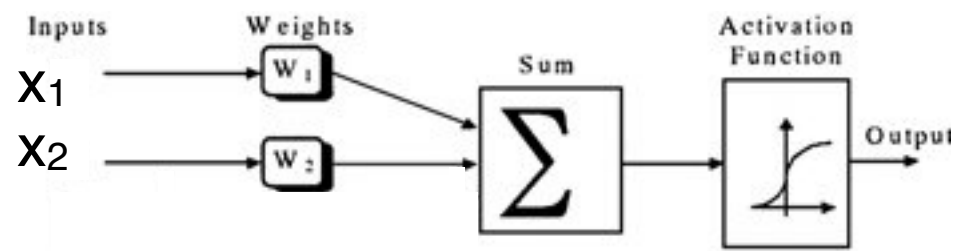

useless?

Is Linear Regression Too Restrictive?

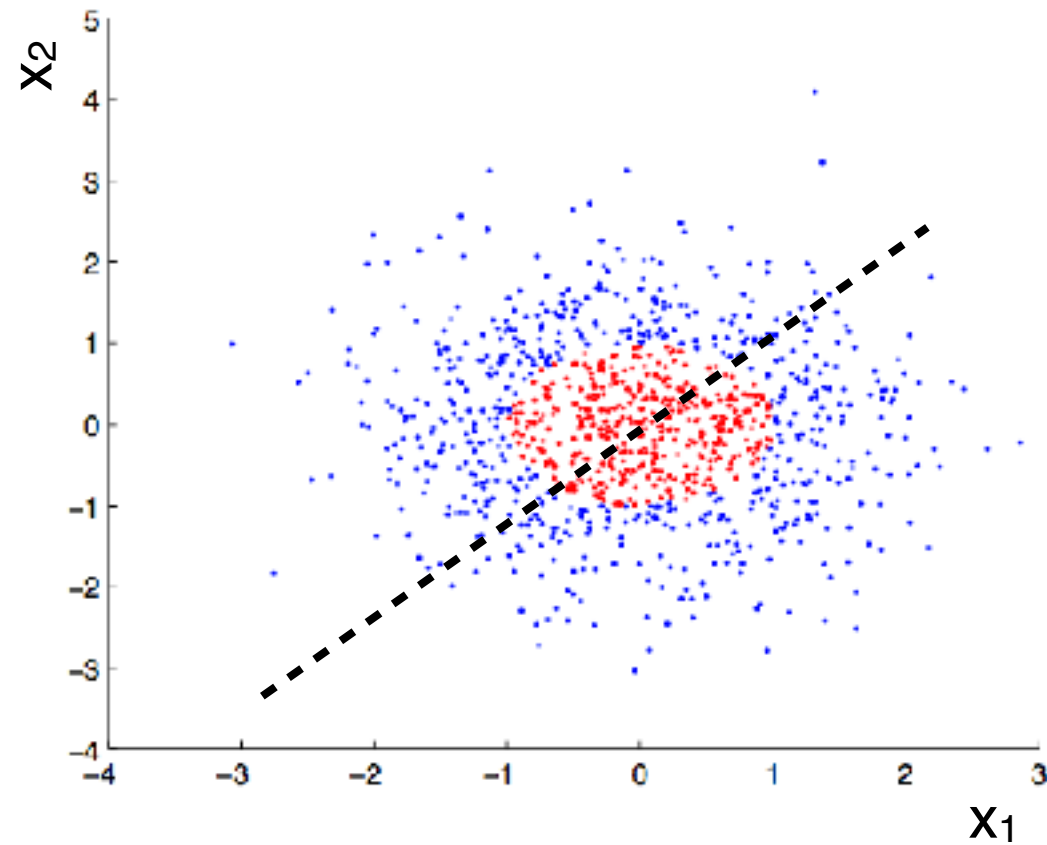
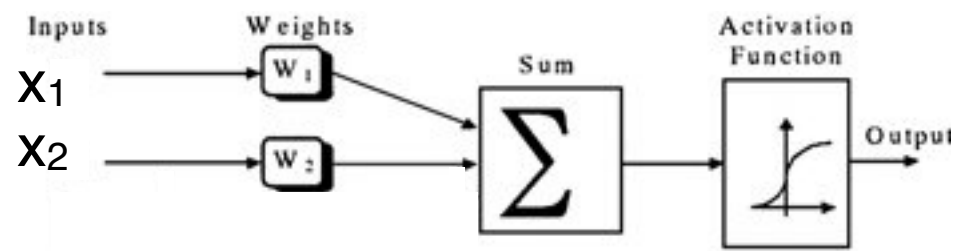

useless?

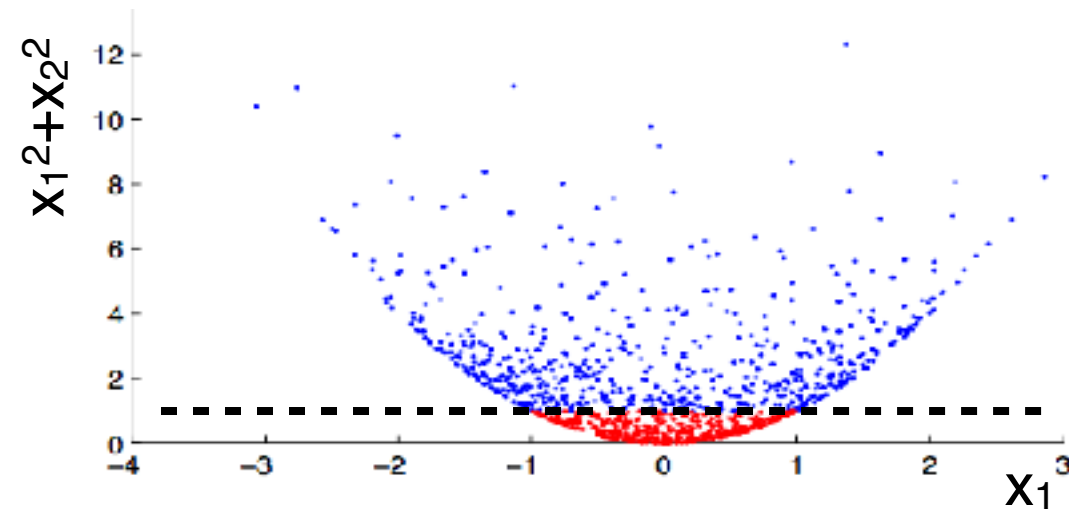
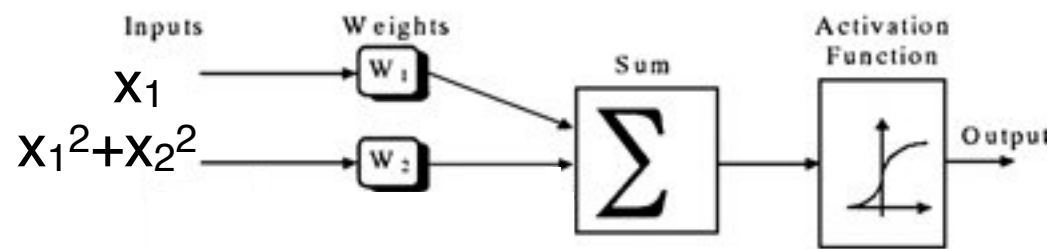

easy!

It's all about selecting good features

Outlook

- ◇ Models and data
- ◇ Formal set of the ML problem
- ◇ Practical points
- ◇ Logistic regression
- ◇ **Figures of Merit**
- ◇ Models optimization
- ◇ Decision Trees
- ◇ Neural networks basics
- ◇ Neural Networks heuristics
- ◇ Illustrations
- ◇ Concluding remarks

Figures Of Merit

For the regression e.g. χ^2 on the test sample is a reasonable FOM

What is a good FOM for classification problem?

Given a labeled sample $X^\ell = \{(\mathbf{x}_i, y_i)\}_{i=1}^\ell$, $y_i \in \{-1, +1\}$, and some candidate h , **how well does h perform on X^ℓ ?**

Let the thresholded decision rule be $a(x) = [h(x) > t]$ (t : hyperparameter)

Obvious choice: **accuracy**

$$\text{accuracy}(a, X^\ell) = \frac{1}{\ell} \sum_{i=1}^{\ell} [a(\mathbf{x}_i) = y_i]$$

However e.g. for sample with 50 signal and 950 background events, classifier “all is background” has accuracy = 0.95

Confusion Matrix

	Label $y = 1$	Label $y = -1$
Decision $a(x) = 1$	True Positive (TP)	False Positive (FP)
Decision $a(x) = -1$	False negative (FN)	True Negative (TN)

Rates are often more informative:

background fake rate \rightarrow False Positive Rate aka FPR = $\frac{FP}{FP + TN}$,

signal efficiency \rightarrow True Positive Rate aka TPR = $\frac{TP}{TP + FN}$,

While accuracy can be expressed, too

$$\text{accuracy} = \frac{TP + TN}{TP + FP + FN + TN}$$

Receiver Operating Curve

Often $h(\mathbf{x})$ is more valuable than its thresholded version $a(x) = [h(x) > t]$

Consider two-dimensional space with coordinates $(\text{TPR}(t), \text{FPR}(t))$, corresponding to various choices of the threshold t

The plot $\text{TPR}(t)$ vs. $\text{FPR}(t)$ is called the **receiver operating characteristic (ROC) curve**

Area under curve (ROC-AUC) reflects classification quality

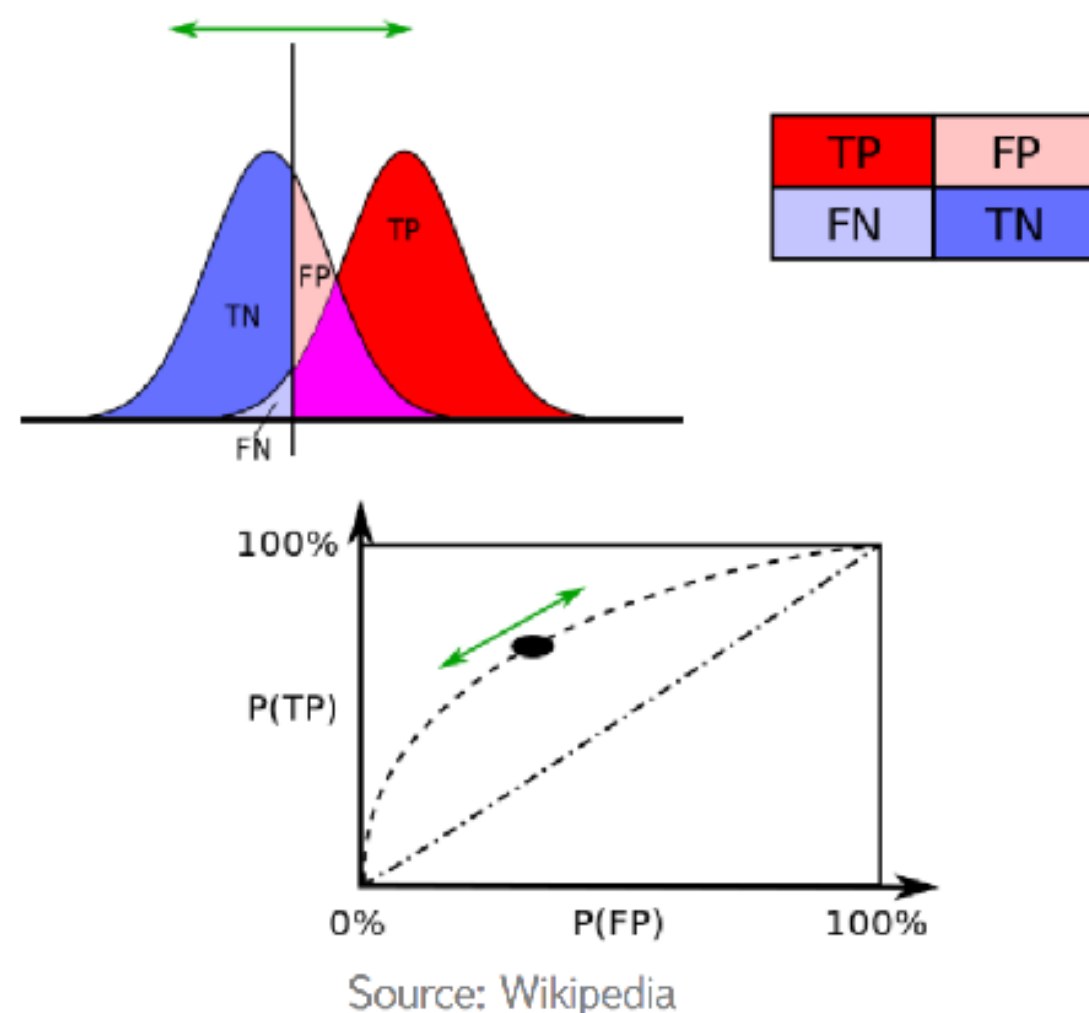

$$\text{TPR} = \frac{\text{TP}}{\text{TP} + \text{FN}},$$

$$\text{FPR} = \frac{\text{FP}}{\text{FP} + \text{TN}},$$

ROC History

WWII: studying algorithms to correctly detect Japanese aircrafts using radars



ROC and ROC-AUC were found a good figures to quantify receiver ability to correctly detect aircraft from the radar signal



ROC Curve Demonstration

<http://arogozhnikov.github.io/2015/10/05/roc-curve.html>

ROC curve demo

mean #1: mean #2: variance #1: variance #2:

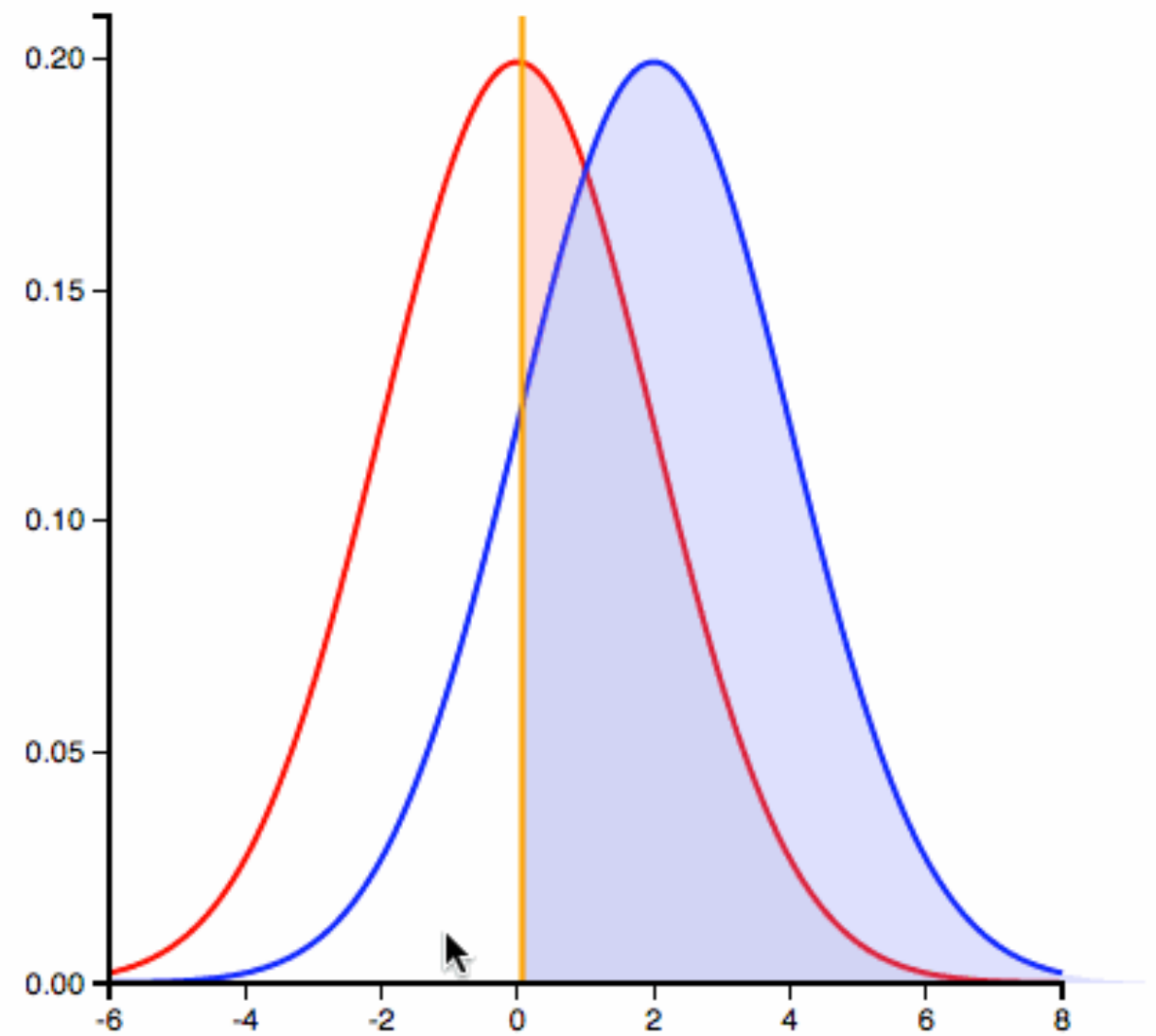
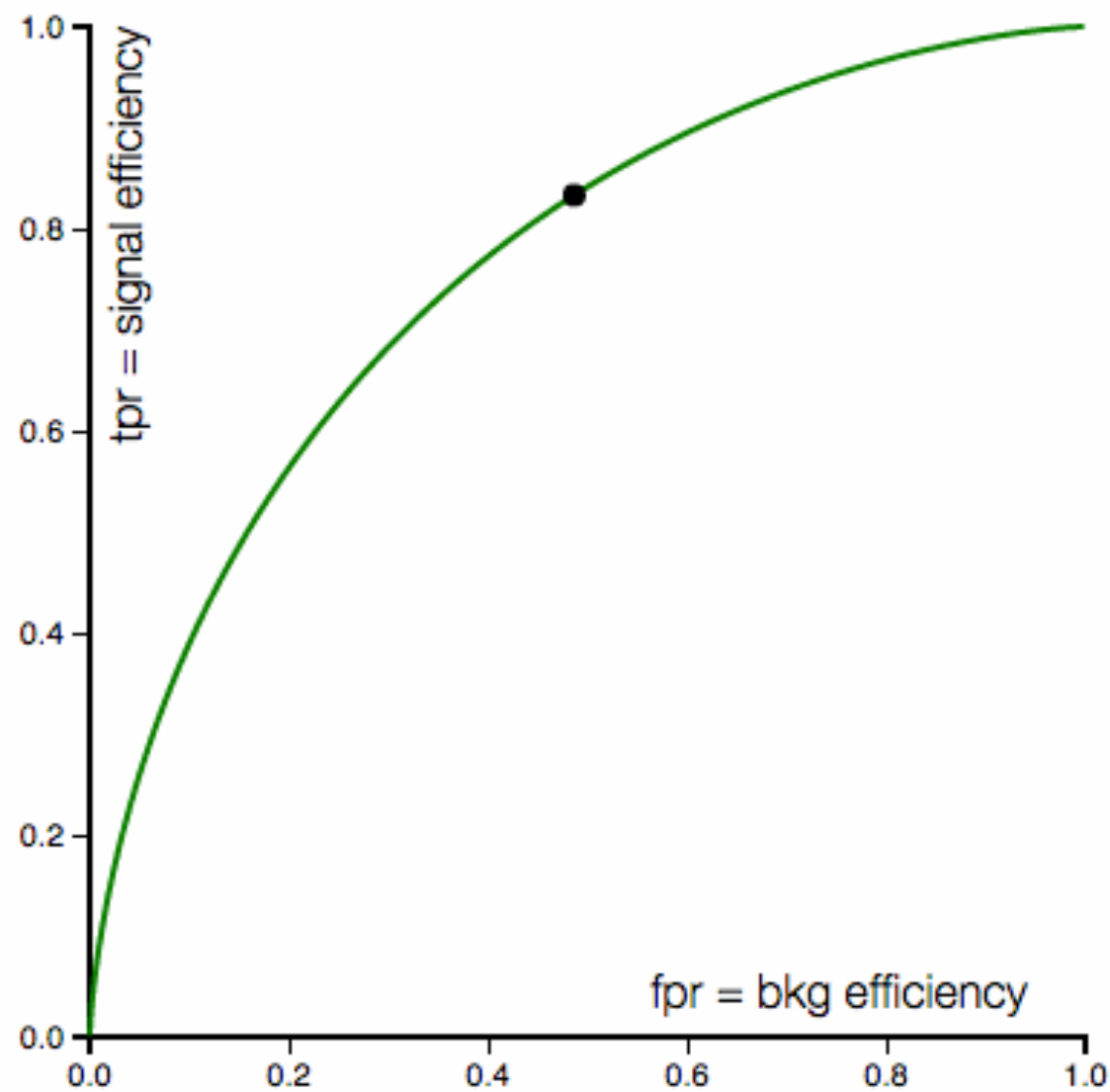

ROC Curve

output of binary classifier is a real variable

say, **signal** and **background**

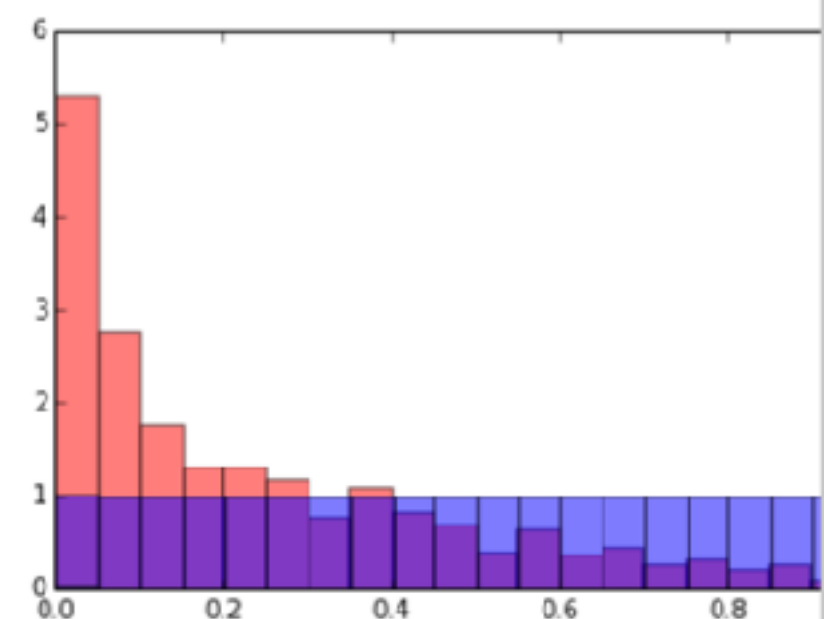
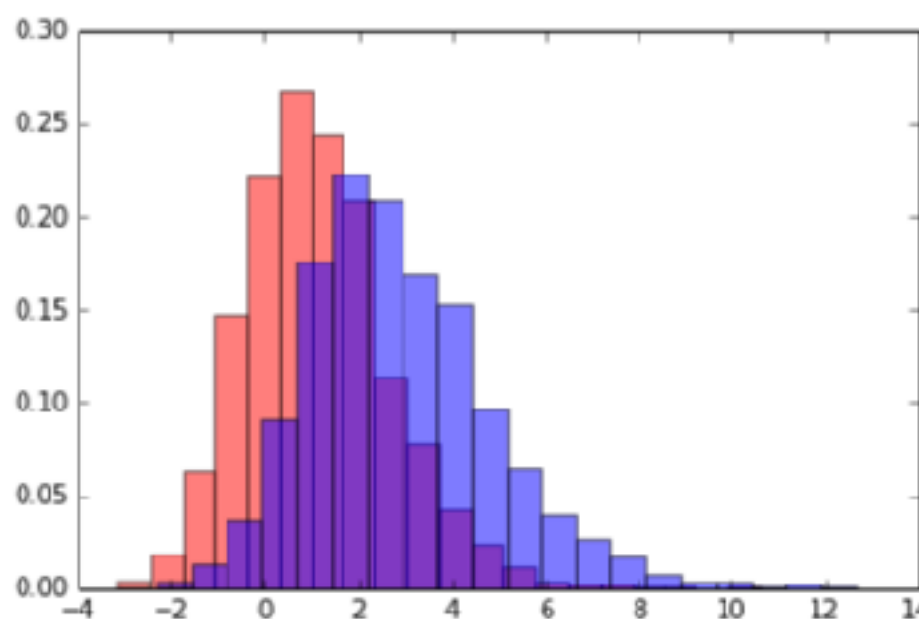
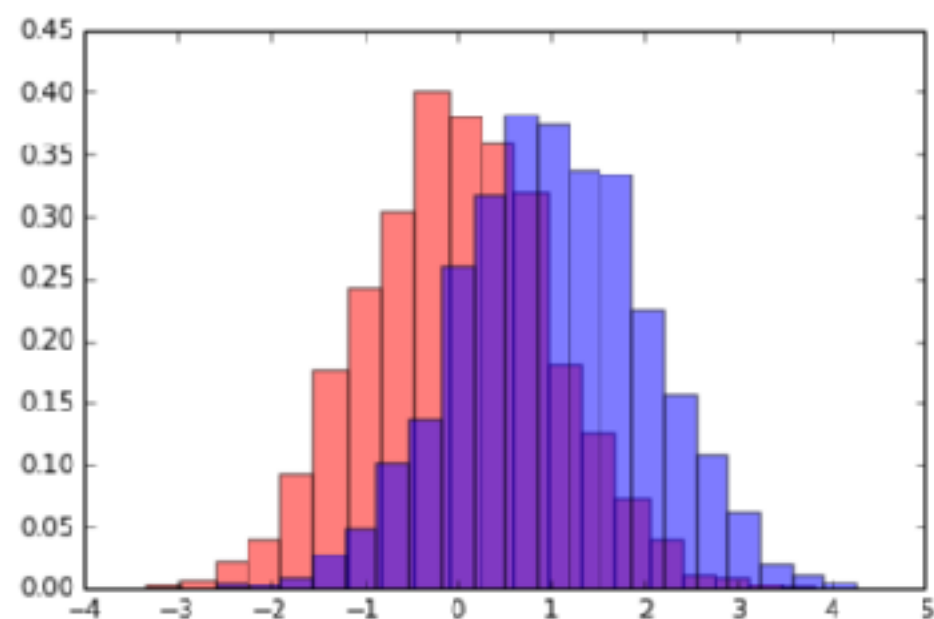

which classifier provides better discrimination?

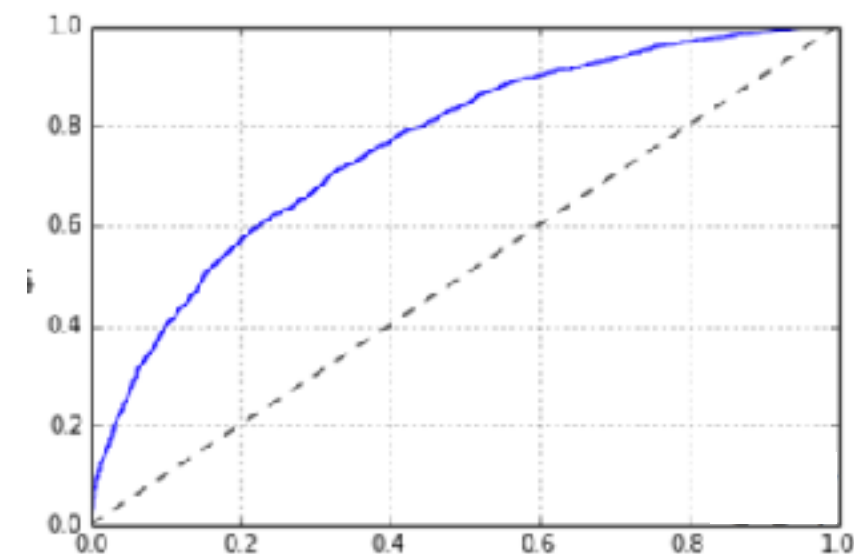

ROC Curve

Defined only for binary classification

Contains important information:

all possible combinations of signal and background efficiencies you may achieve by setting threshold

Particular values of thresholds (and initial pdfs) don't matter, ROC curve doesn't contain this information

ROC curve = information about order of events:

bbsbsb ... ssbss

Comparison of algorithms should be based on the information from ROC curve

ROC-AUC

ROC-AUC: Area Under ROC Curve

$$\text{ROC-AUC} = P(r_b < r_s)$$

r_b and r_s are predictions for random background and signal events

The bigger ROC-AUC, the stronger separation is

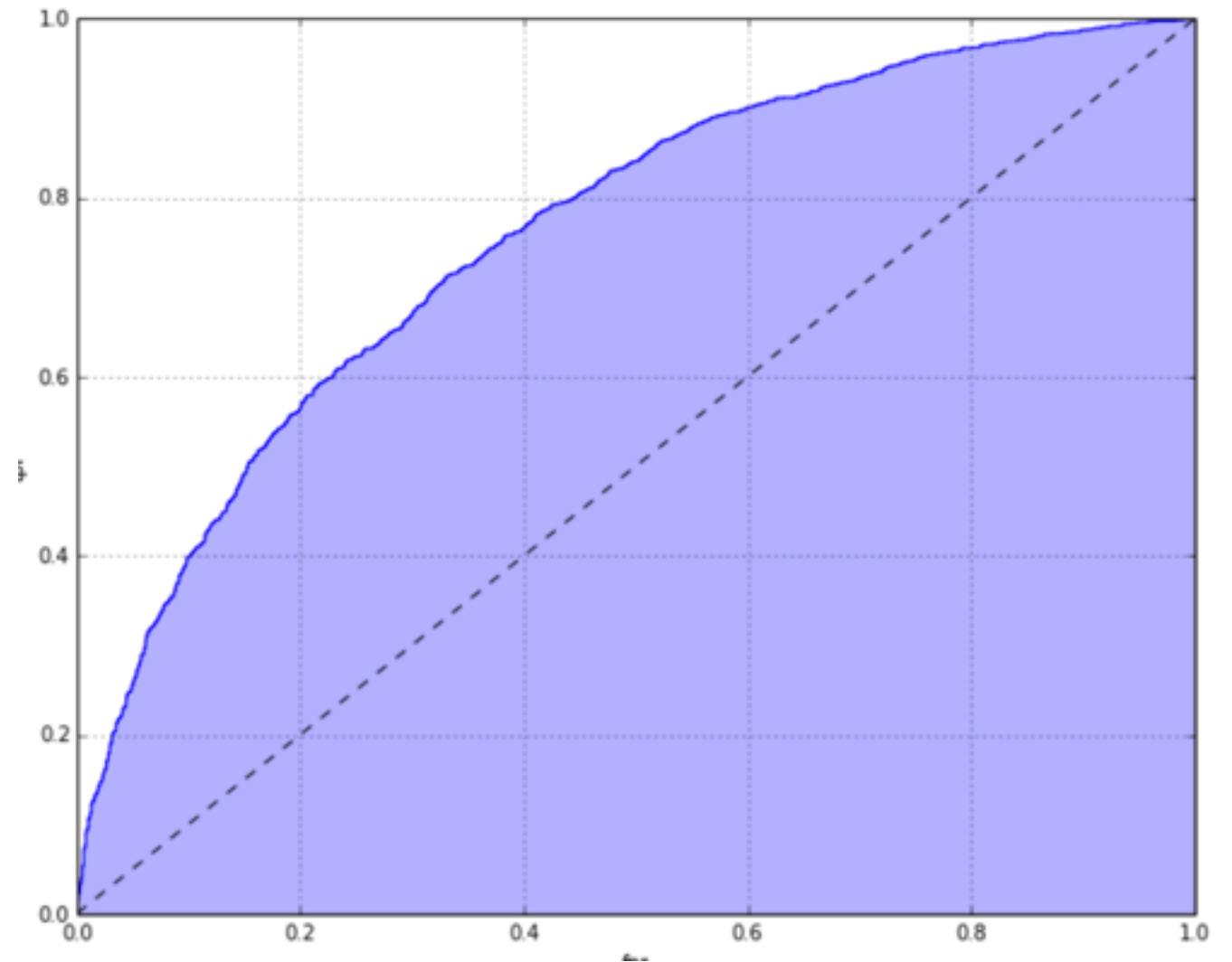

Selecting Good Classifier

ROC AUC is a measure of separation ability of the classifier

Is larger always better?

These these are two classifiers for trigger selection at LHC

which one should be used?

NB we are limited by the trigger rate and need few background events to pass

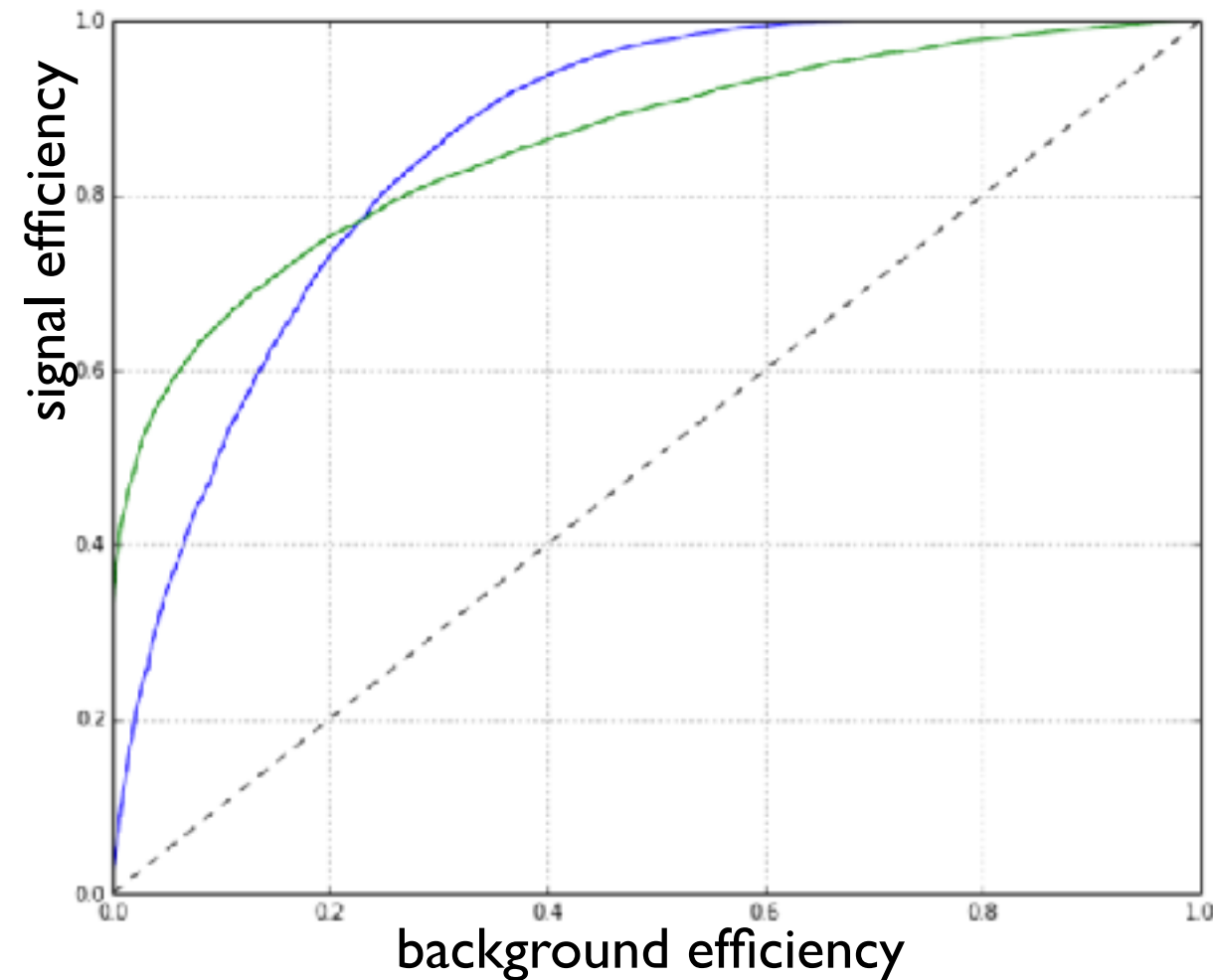

Outlook

- ◇ Models and data
- ◇ Formal set of the ML problem
- ◇ Practical points
- ◇ Logistic regression
- ◇ Figures of Merit
- ◇ **Models optimization**
 - ◇ assess model quality: cross-validation
 - ◇ optimizing model parameters: hyperparameters tuning
- ◇ Decision Trees
- ◇ Neural networks basics
- ◇ Neural Networks heuristics
- ◇ Illustrations
- ◇ Concluding remarks

Model Validation and Selection

our model has free parameters (hyperparameters)

e.g. polynomial degree n for P_n regression, subset of features in multivariate regression etc.

model selection: how to choose optimal hyperparameters for the given problem

after training we obtain some model performance

model validation: how to evaluate true performance

(NB overfitting)

solution: hold some data apart when training the model, use them for *unbiased* validation and optimization of the model

Model Validation

- ◇ split data $X = X_{train} + X_{val}$
- ◇ **train model** $g(x, \theta)$ on X_{train}
 - ◇ find optimal parameters θ_0 and optimal model $g_0(x) = g(x, \theta_0)$
- ◇ **assess quality**, e.g. $Q(g_0(x), X_{val})$
- ◇ we got unbiased quality estimation, but no idea about its precision
 - ◇ result depends on the particular data split

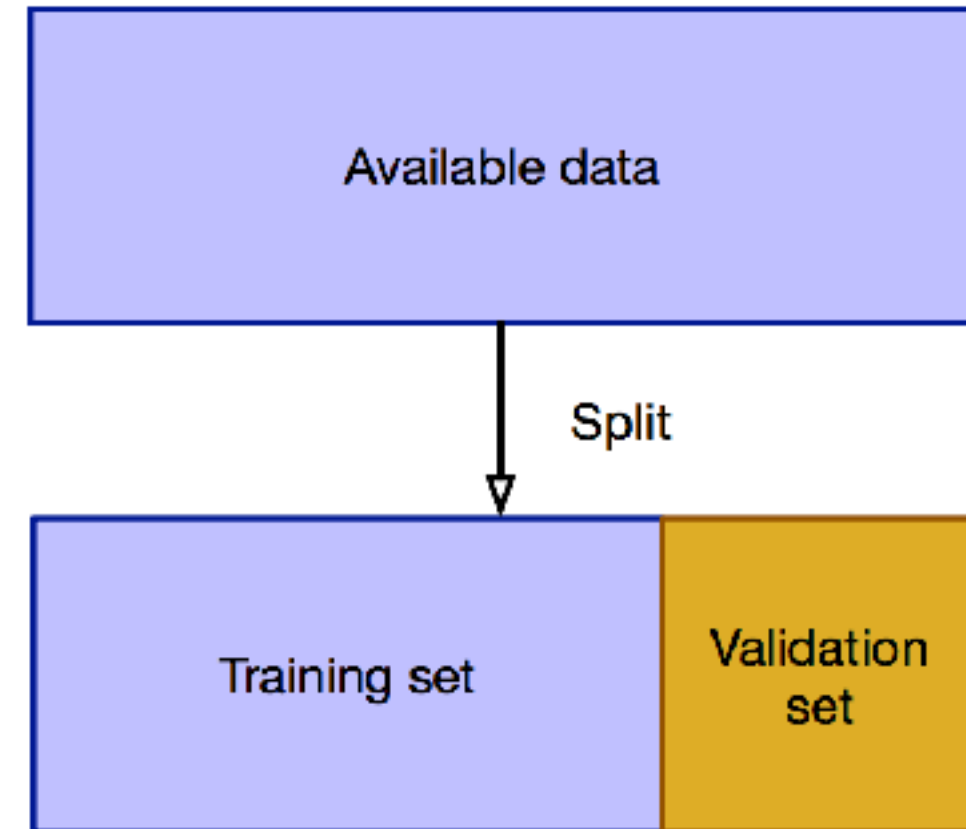

K-fold Cross Validation

- ◇ split data $X = X_1 + X_2 + \dots + X_K$ of equal sizes
- ◇ **train K models** $g_i(x), i=1..K$
 - ◇ each model is trained on all subsets except X_i
- ◇ **assess K qualities**, on remaining subset, e.g. $Q(g_i(x), X_i)$
- ◇ we got K estimations for quality, may derive average and variance
- ◇ most effective use of available dataset

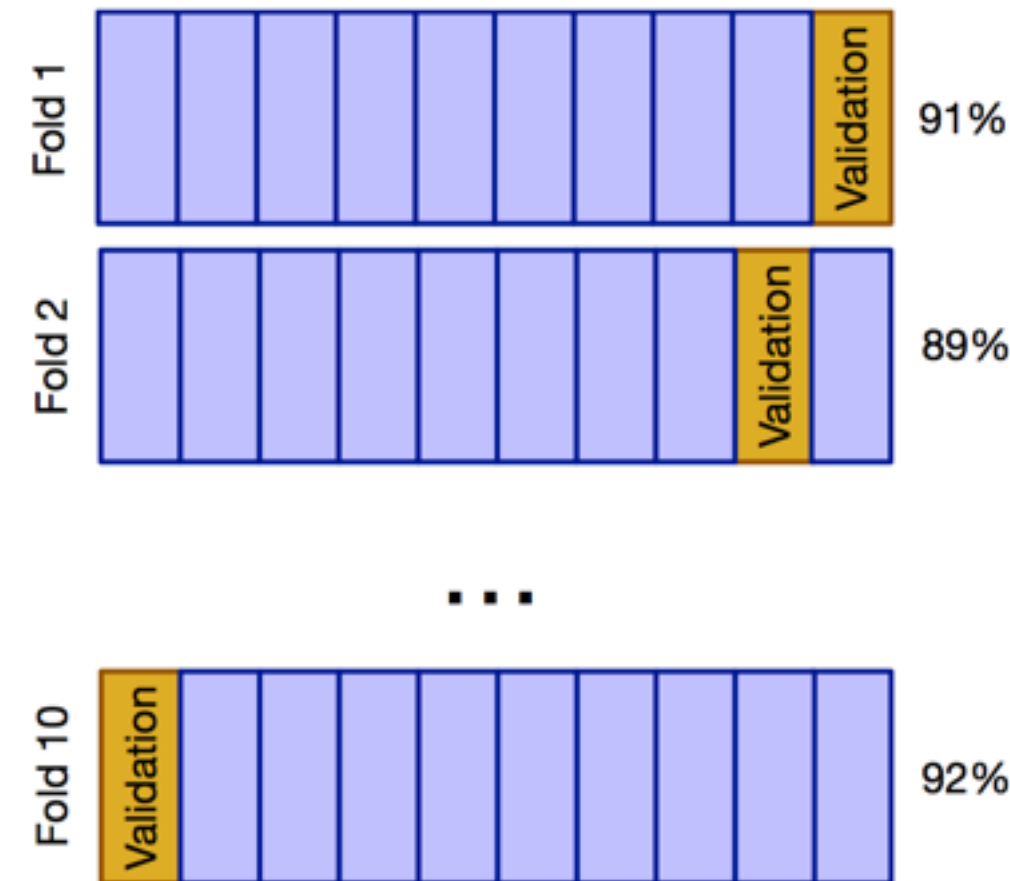

K-Fold Cross Validation Tradeoffs

- ◇ many folds:
 - ◇ small bias comparing to training on the full dataset
 - ◇ large variance due to small test size
 - ◇ large computational time due to many experiments
- ◇ few folds:
 - ◇ computationally effective
 - ◇ small variance
 - ◇ larger bias with respect to the training on the full dataset
- ◇ mean and variance of the Q in CV gives a good idea about quality and stability of the model

Model Optimization

- ◇ with cross-validation we can evaluate quality of the model
- ◇ but we can use different models
- ◇ how to select the best one?
 - ◇ e.g. which degree d to select for P_n regression?
- ◇ solution: consider it as a yet another optimization problem
 - ◇ describe variety of models by few **hyperparameters**
 - ◇ optimize hyperparameters

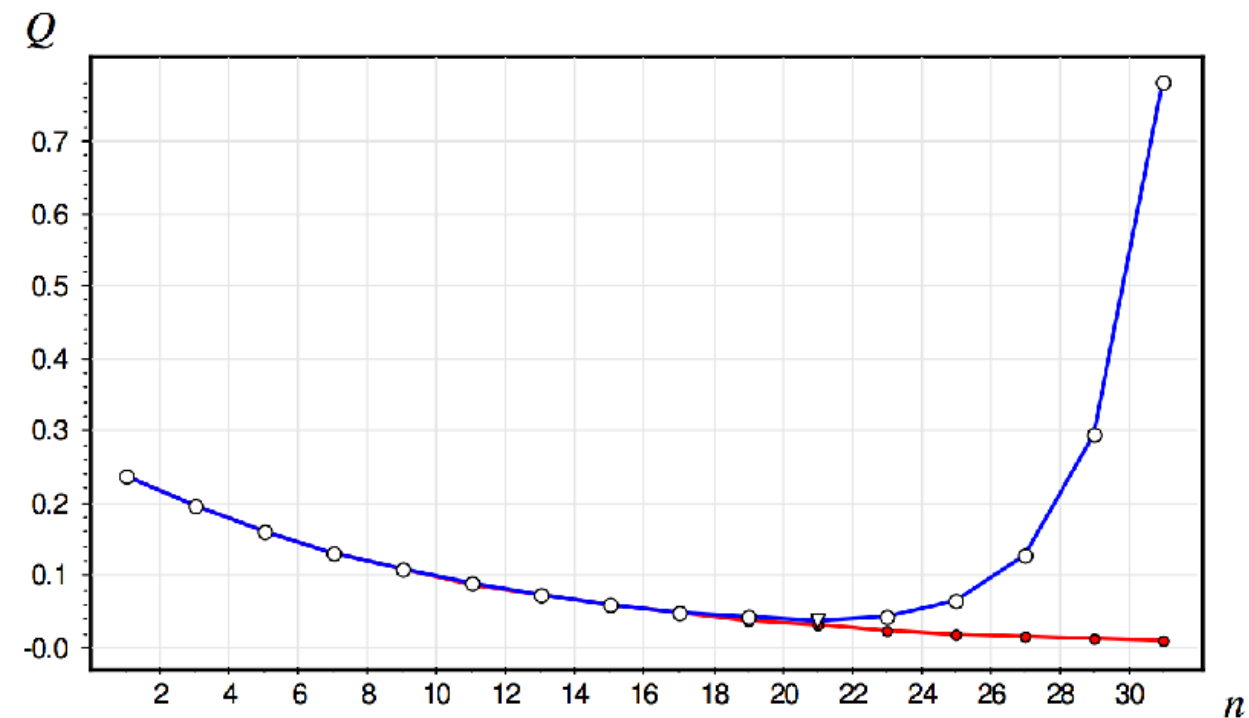

Hyperparameters Optimization

- ◇ what is the figure of merit?
 - ◇ e.g. mean quality on cross-validation
- ◇ on which data?
 - ◇ validation subset must be **statistically independent** from both train and validation subsets
- ◇ which approach?
 - ◇ until number of hyperparameters is small, simple grid search may be good enough
 - ◇ otherwise black-box optimization approaches/tools may be employed
 - ◇ to speedup converging and increasing precision

Hyperparameters Optimization

- ◇ optimisation tools
 - ◇ hyperopt
 - ◇ SMAC3
 - ◇ GPyOpt
 - ◇ scikit-optimize
 - ◇ bayesopt
 - ◇ modelgym
- ◇ difference
 - ◇ sequential/distributed/parallel execution
 - ◇ surrogate model family
 - ◇ support from the developers

Outlook

- ◇ Models and data
- ◇ Formal set of the ML problem
- ◇ Practical points
- ◇ Logistic regression
- ◇ Figures of Merit
- ◇ Models optimization
- ◇ **Neural networks basics**
 - ◇ intuition
 - ◇ mathematical basics
 - ◇ backpropagation
- ◇ Neural Networks heuristics
- ◇ Decision Trees
- ◇ Illustrations
- ◇ Concluding remarks

Outlook

- ◇ Models and data
- ◇ Formal set of the ML problem
- ◇ Practical points
- ◇ Logistic regression
- ◇ Figures of Merit
- ◇ Models optimization
- ◇ **Decision Trees basics**
- ◇ Neural networks basics
- ◇ Neural Networks heuristics
- ◇ Illustrations
- ◇ Concluding remarks

ML Basic Concept

- ◇ Machine Learning is a technical way to build generic model for the given dataset
 - ◇ inputs, outputs or goals may be very different though
 - ◇ classification
 - ◇ pattern recognition
 - ◇ text, speech, vision, etc.
 - ◇ new object generation
 - ◇ action control
 - ◇ games, driving, etc.
 - ◇ ...
- ◇ **Key requirement: there is a way to effectively train the model**

Decision Trees for Regression

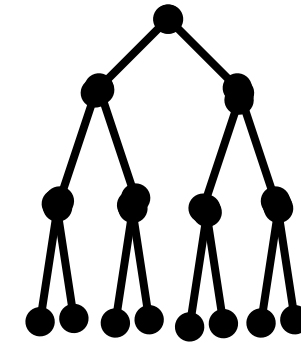
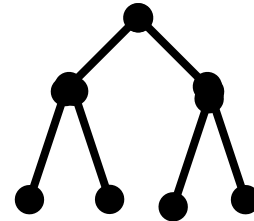
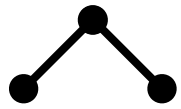

Regression Tree, depth 1

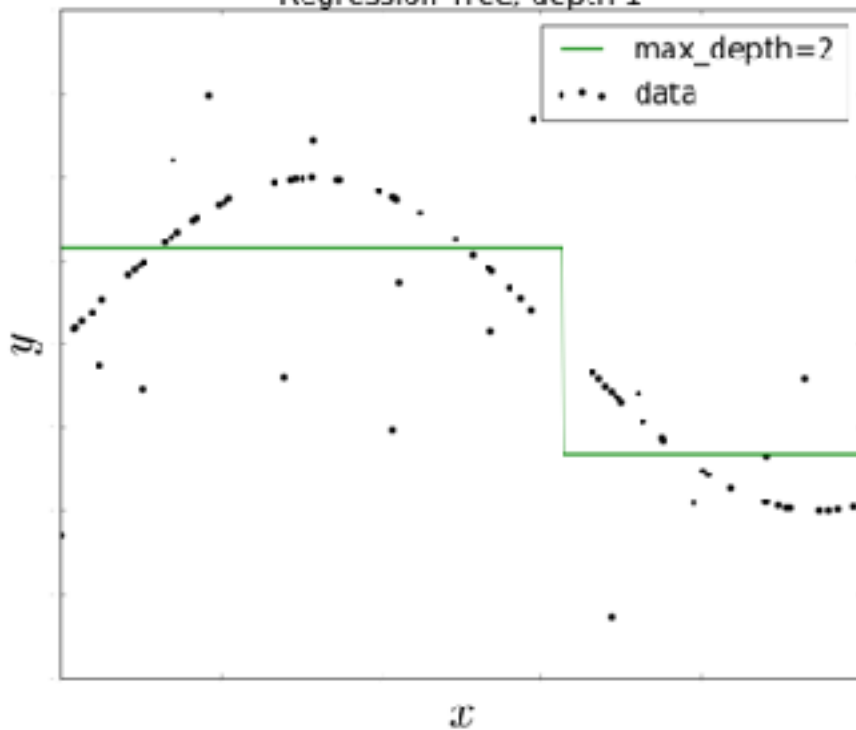

Regression Tree, depth 2

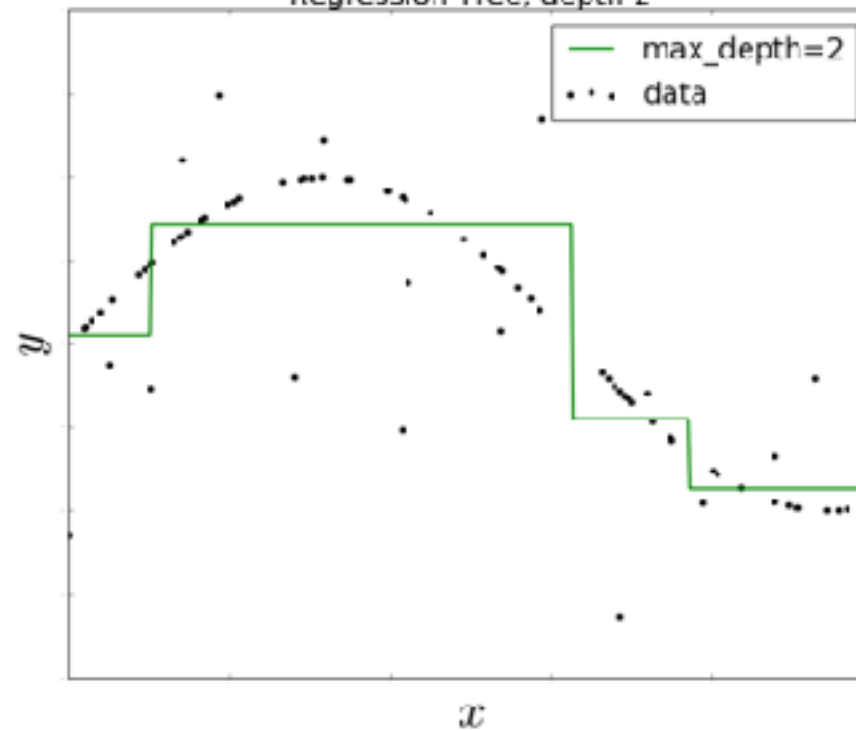

Regression Tree, depth 3

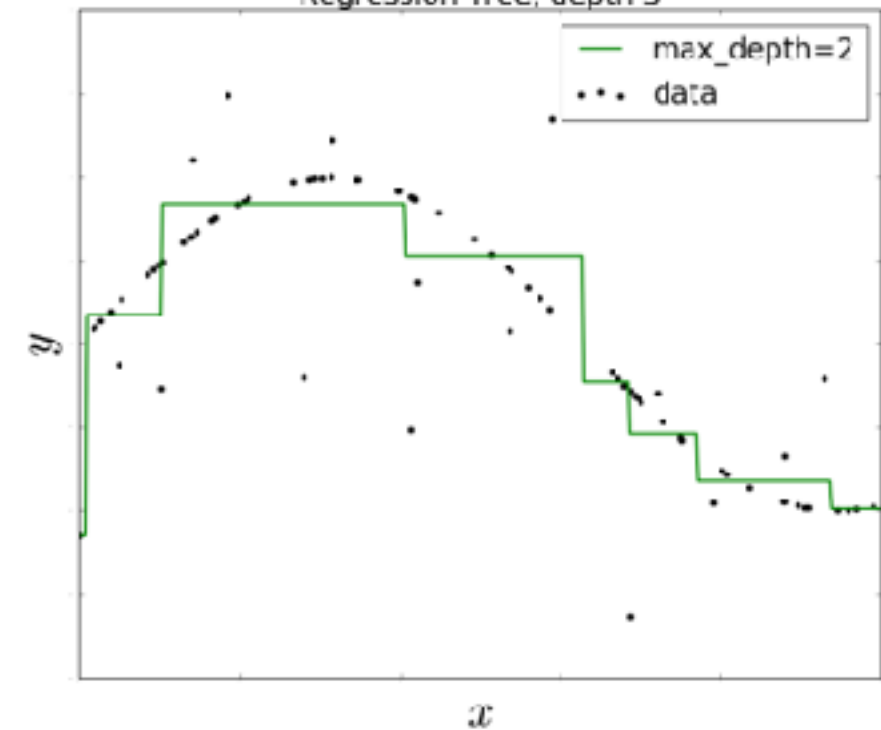

- ◇ Build tree, optimize MSE in leafs
 - ◇ use greedy algorithm on every step

Ensembling Models

- ◇ Trees are not stable
 - ◇ small variations in data drastically affect the split to branches
- ◇ Use it for good
 - ◇ build different trees - ensemble of solutions
 - ◇ average them
 - ◇ get more stable result
- ◇ Approaches
 - ◇ bagging
 - ◇ boosting

Bagging (Bootstrap Aggregation)

- ◇ Select training subset from data randomly with replacement
- ◇ Build tree for every subset
- ◇ Average all predictions - Profit!

- ◇ Random Forest
 - ◇ bagging
 - ◇ and also chose a subset of input features randomly for every subset
- ◇ Allows to maintain high dimensibility in shallow trees

Boosting

- ◇ Make a sequence of predictors
 - ◇ next predictor corrects mistakes of the previous one
- ◇ Gradient Boosting
 - ◇ train next predictor on the difference between previous predictor and the actual value
 - ◇ result is a sum of shallow trees
- ◇ XGBoost smart implementation of the GB approach
 - ◇ parameters: max # of trees, single tree depth

Generic Model: Decision Trees

Deep DT

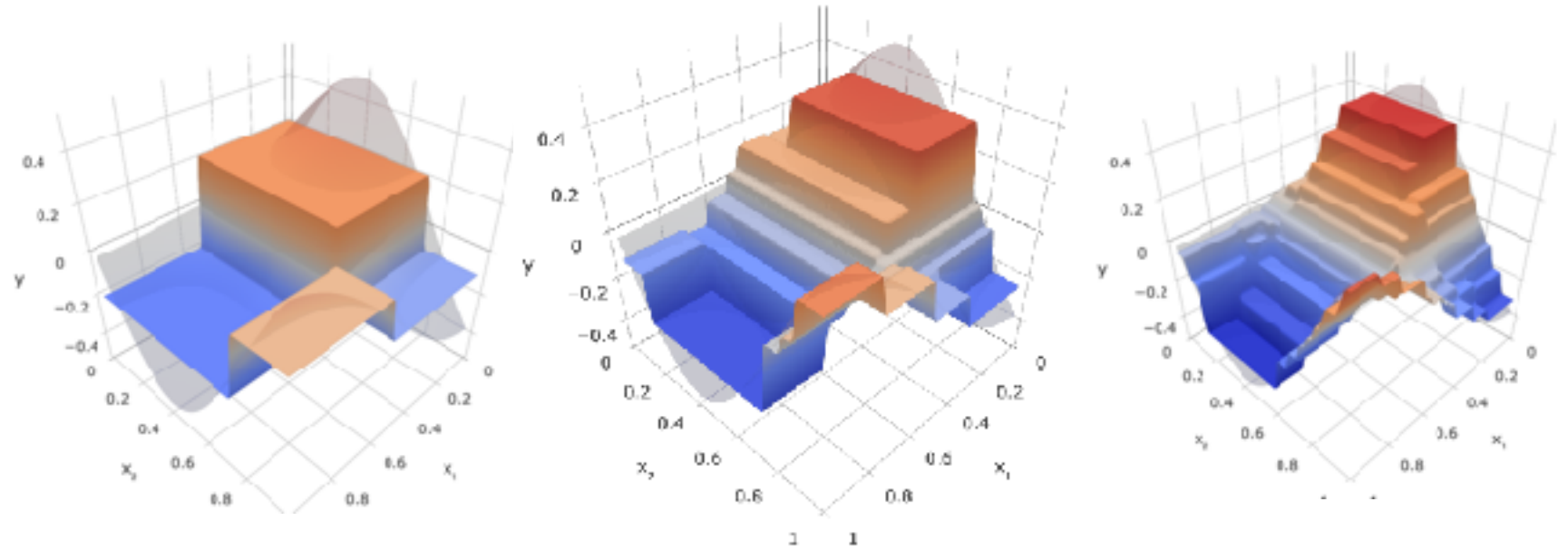
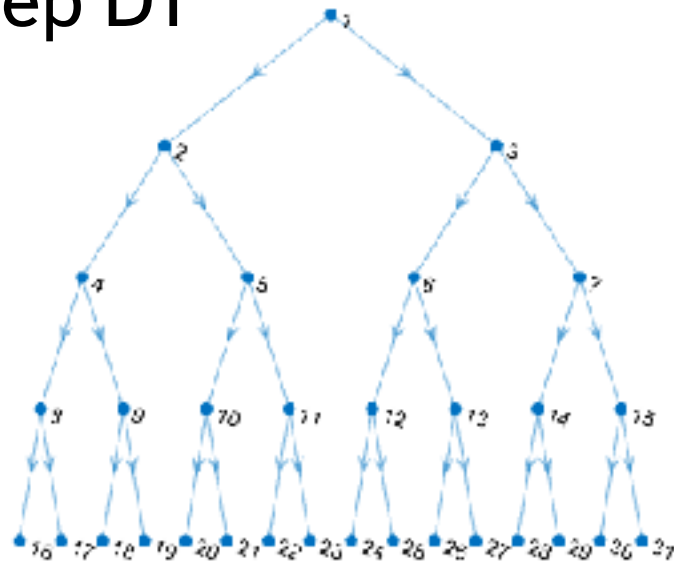

depth=2,4,6 DT

Shallow Boosted DT

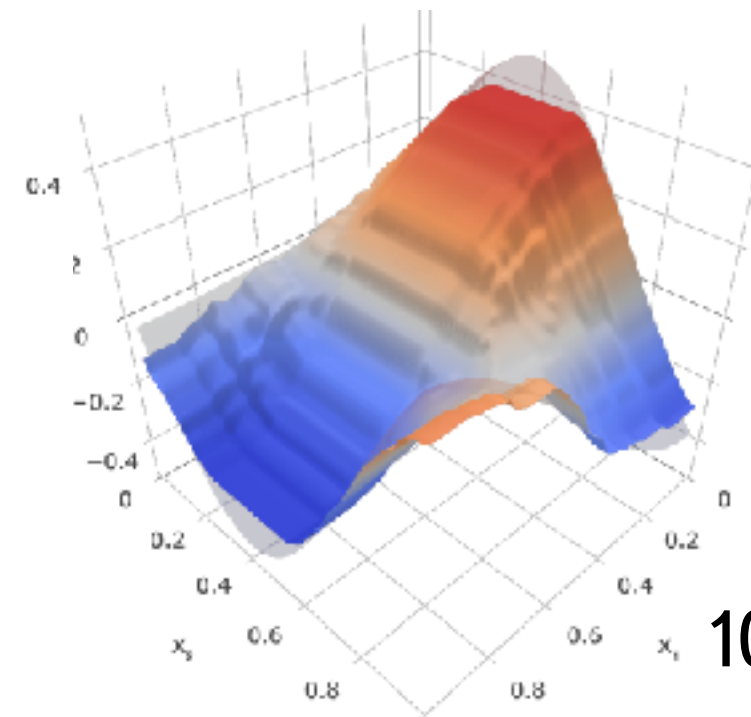
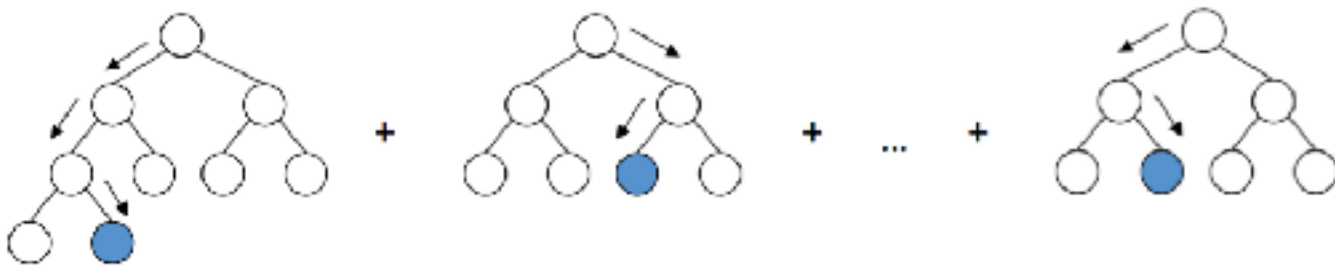

100x depth=3 BDT

http://arogozhnikov.github.io/2016/06/24/gradient_boosting_explained.html

Neural Networks

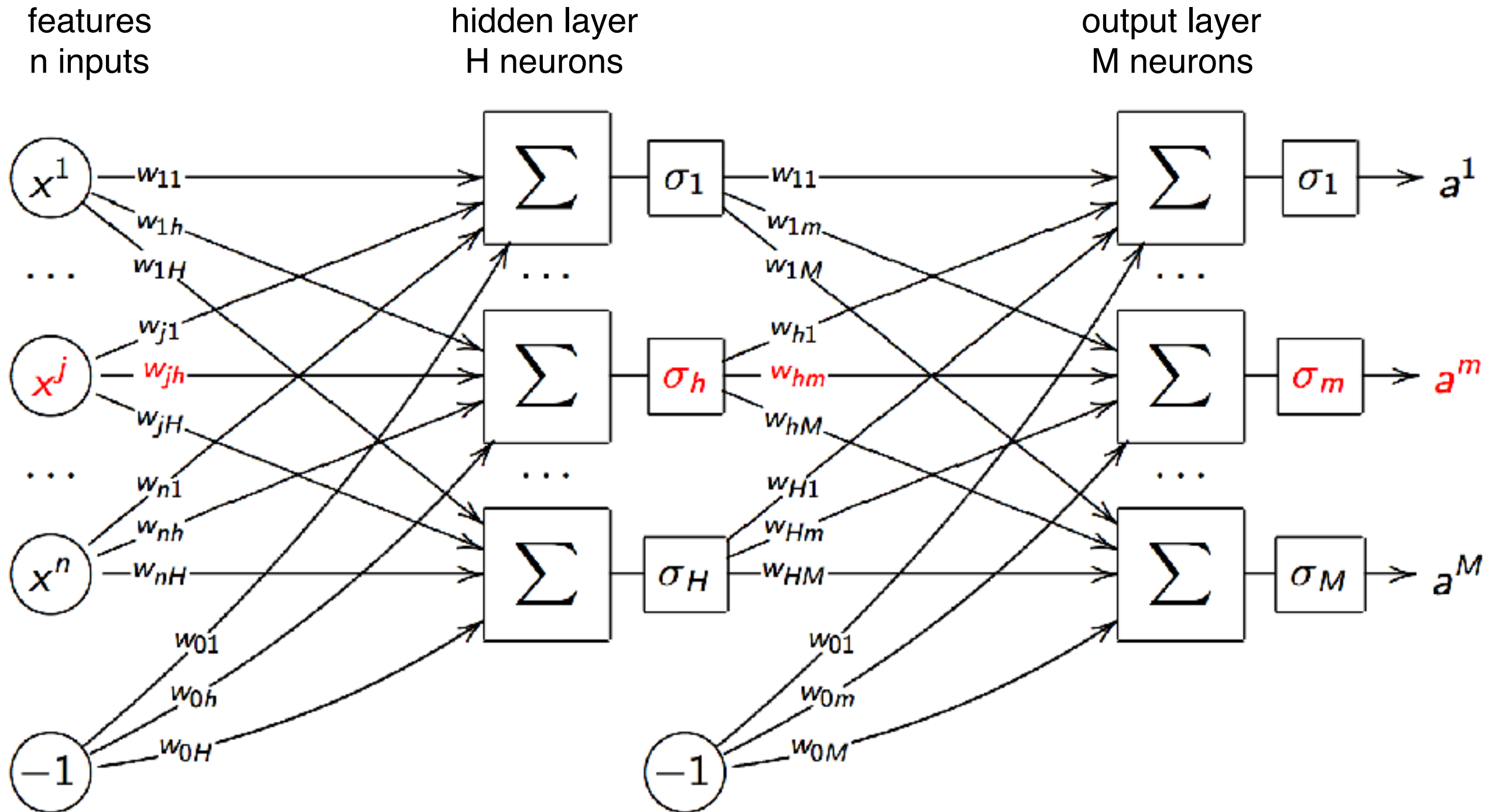

$(n+1)H+(H+1)M$ total model parameters

Neural Network Intuition: Classifier

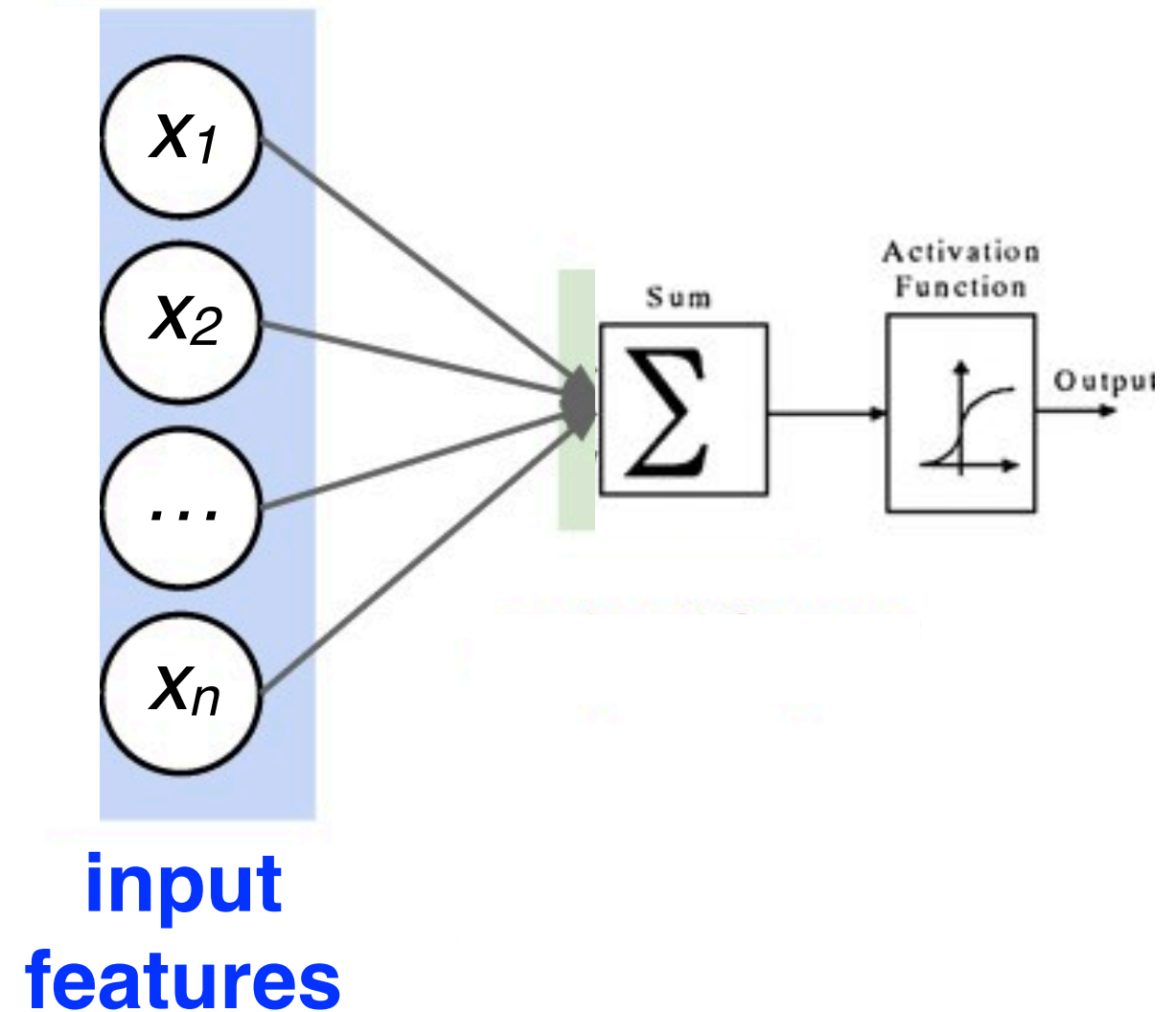
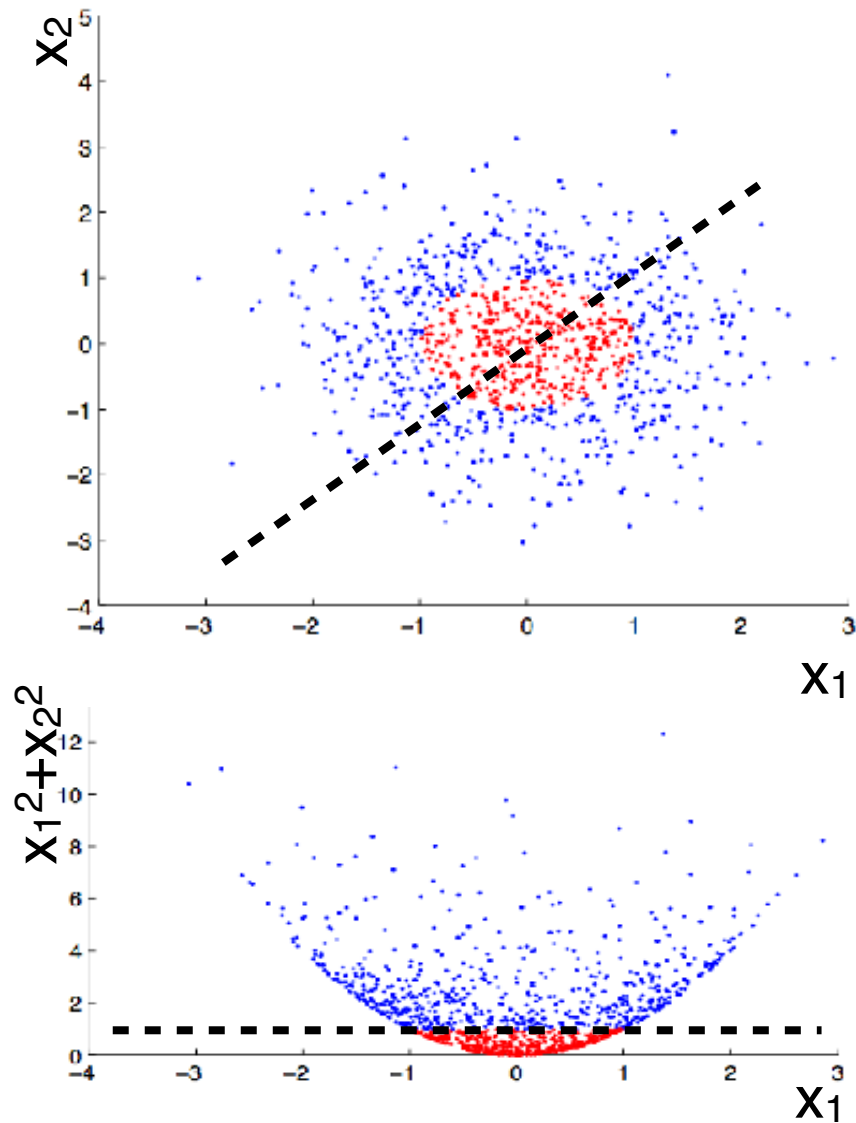

◇ Linear logistic regression

◇ requires decision boundary be a plane in terms of input features

Historical Basis

<https://askbiologist.asu.edu/neuron-anatomy>

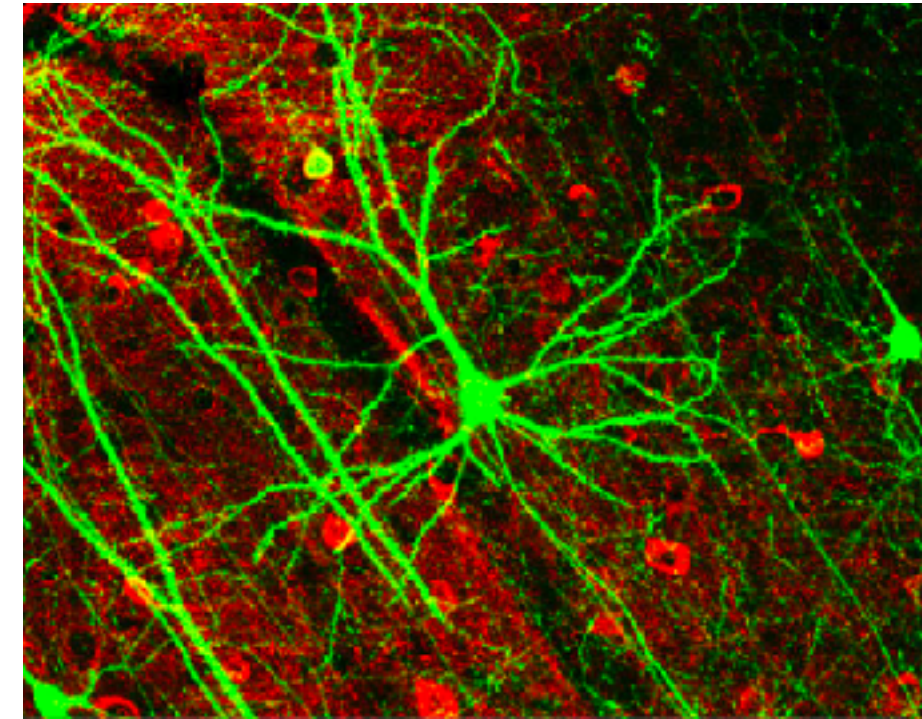
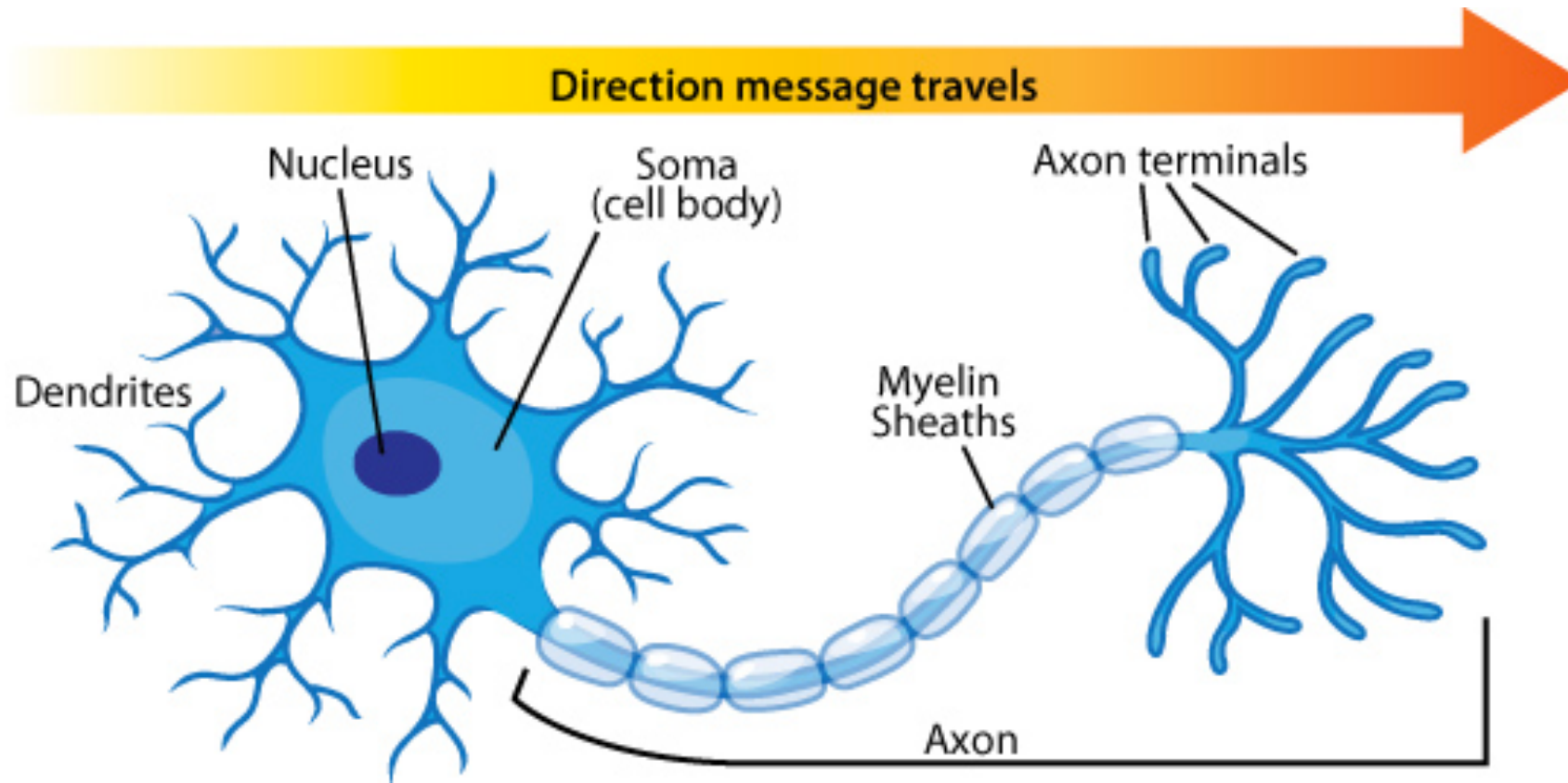

- Nucleus
- Cell Body
- ~ Axon/Synapses
- ~ Dendrites

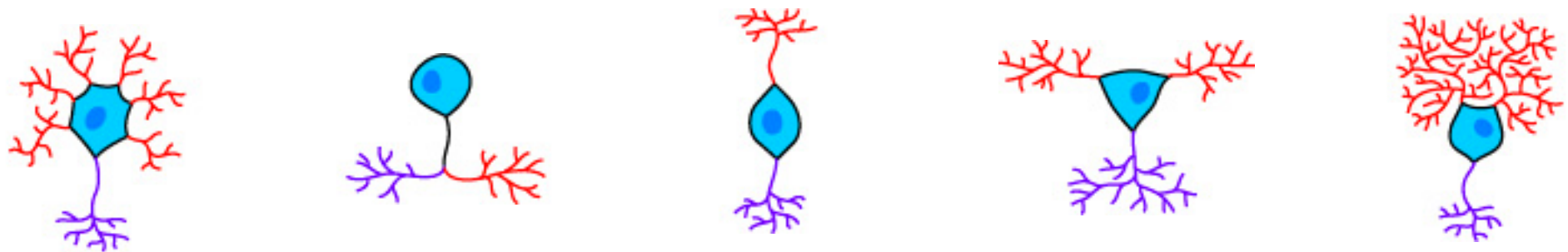

Theoretical Basis

- ◇ Arnold - Kolmogorov (1957):

- ◇ if f is a multivariate continuous function, then f can be written as a finite composition of continuous functions of a single variable and the binary operation of addition

- ◇ Gorban (1998)

$$f(x^1, x^2, \dots, x^n) = \sum_{k=1}^{2n+1} h_k \left(\sum_{i=1}^n \varphi_{ik}(x^i) \right)$$

- ◇ it is possible to obtain arbitrarily exact approximation of any continuous function of several variables using operations of summation and multiplication by number, superposition of functions, linear functions and one arbitrary continuous nonlinear function of one variable.
- ◇ Thus Neural Network is an universal approximator for any continuous function
 - ◇ necessary complexity of the NN is not specified though

Neural Network Intuition: Classifier

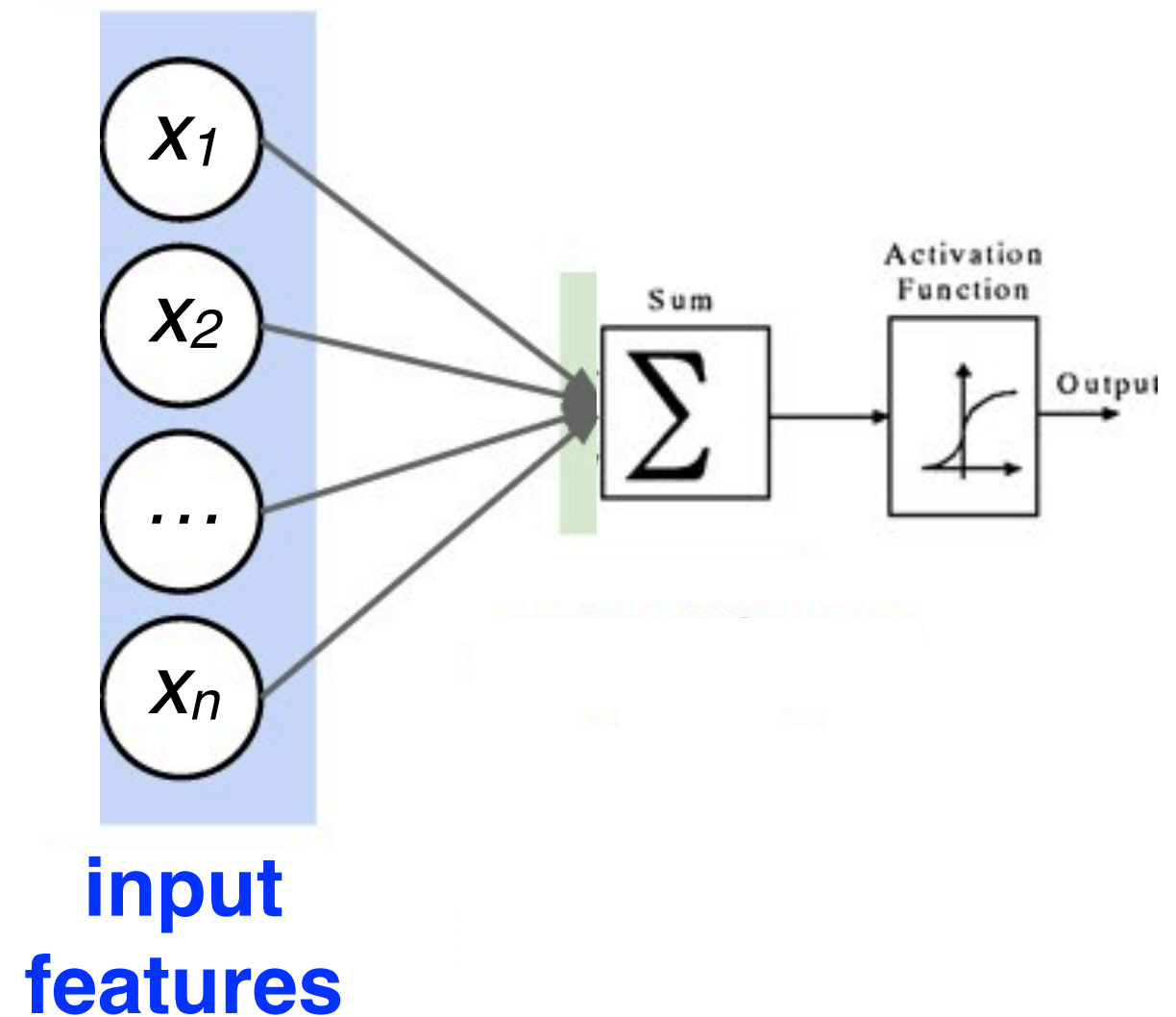
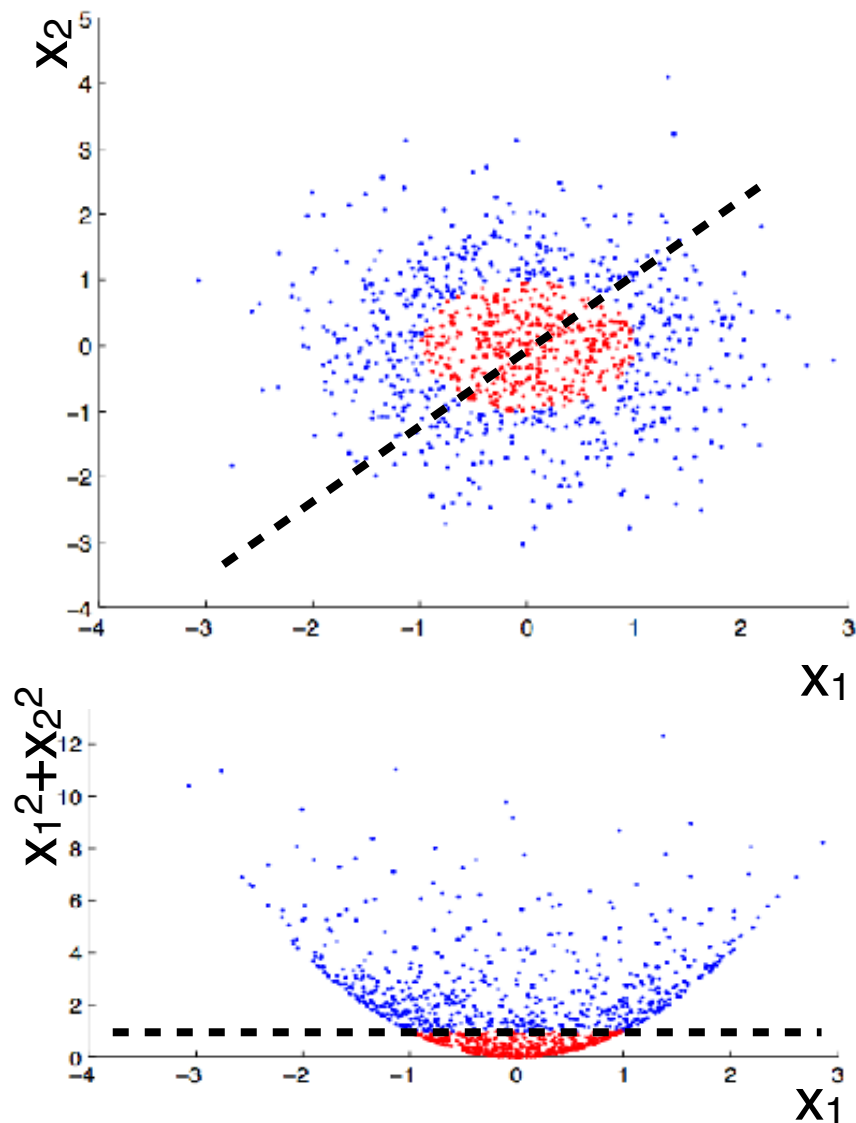

◇ Linear logistic regression

◇ requires decision boundary be a plane in terms of input features

Neural Network Intuition: Building Features

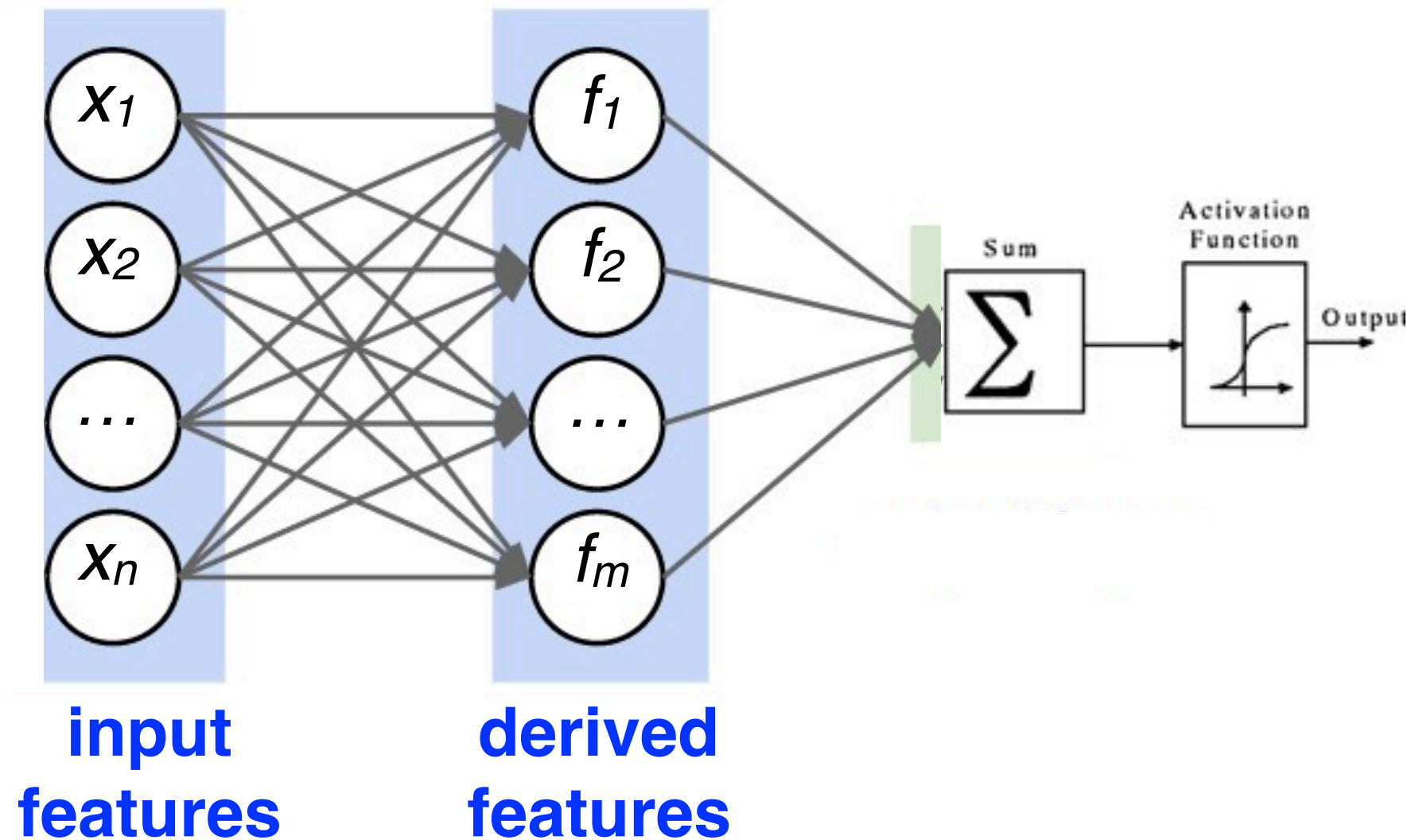

◇ Linear logistic regression

- ◇ use NN layer to construct features more appropriate for linear logistic regression

Neural Network Intuition: Building Features

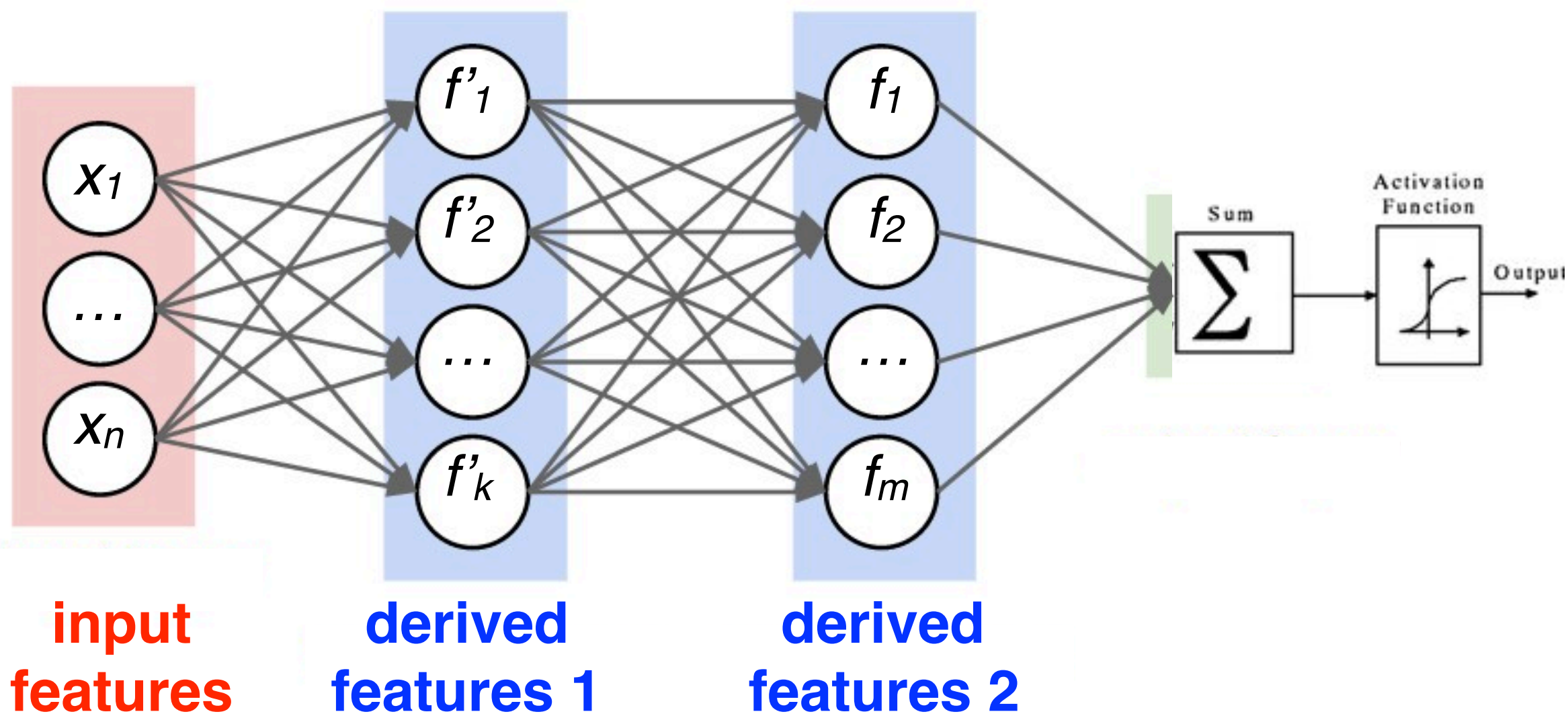

◇ Linear logistic regression

- ◇ use extra NN layer to construct new features which are more appropriate to construct features which are appropriate for linear logistic regression

Backpropagation

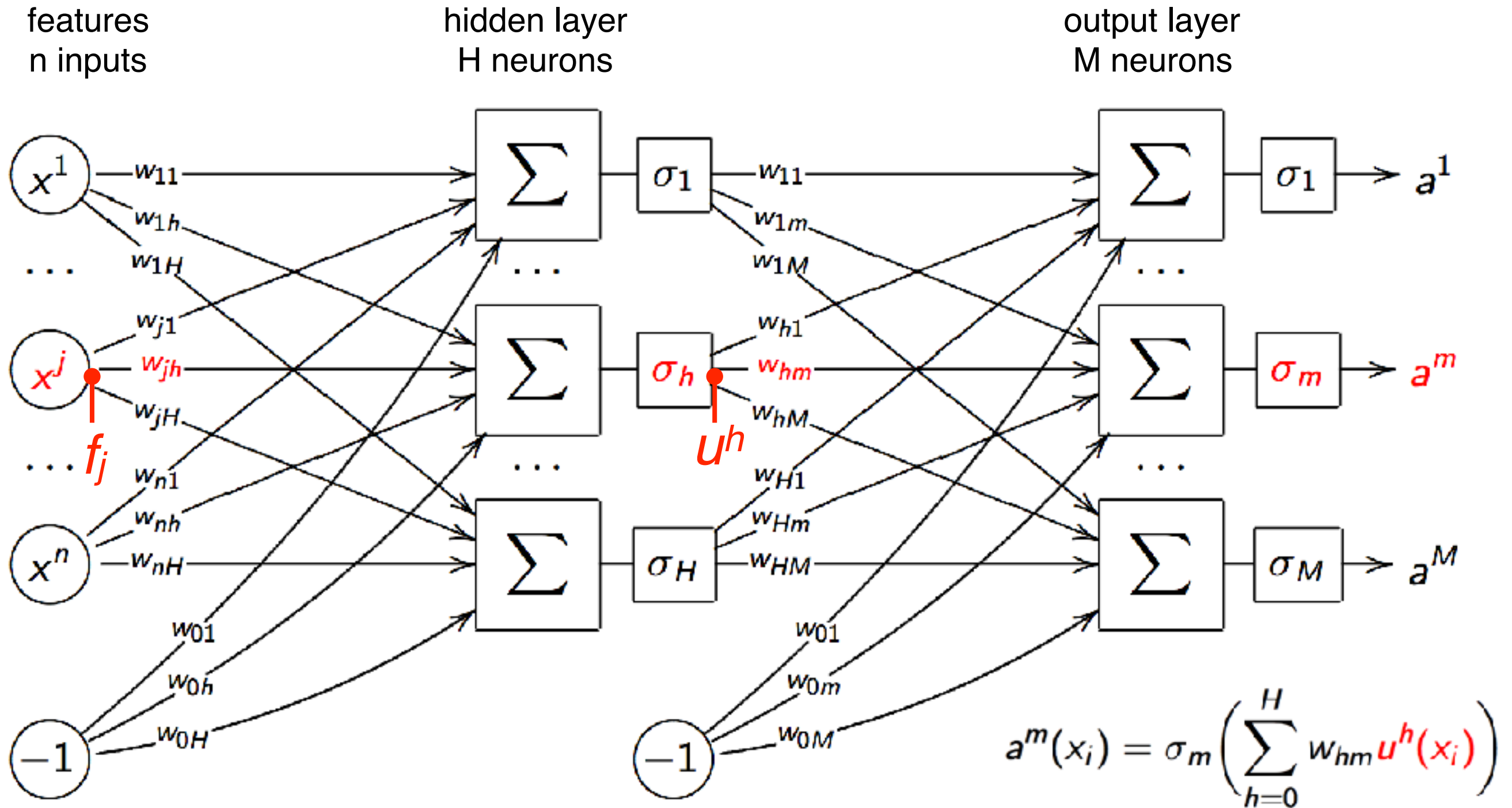

$(n+1)H+(H+1)M$ total model parameters

$$a^m(x_i) = \sigma_m \left(\sum_{h=0}^H w_{hm} u^h(x_i) \right)$$

$$u^h(x_i) = \sigma_h \left(\sum_{j=0}^J w_{jh} f_j(x_i) \right)$$

Loss Variation

- ◇ We want to correct (quadratic) loss by varying w appropriately

- ◇ output layer error:
$$\frac{\partial \mathcal{L}_i(w)}{\partial a^m} = a^m(x_i) - y_i^m = \varepsilon_i^m$$

- ◇ Let's propagate it back to u :

$$a^m(x_i) = \sigma_m \left(\sum_{h=0}^H w_{hm} u^h(x_i) \right)$$

$$\frac{\partial \mathcal{L}_i(w)}{\partial u^h} = \sum_{m=1}^M \frac{\partial \mathcal{L}_i(w)}{\partial a^m} \sigma'_m(\cdot) w_{hm} = \sum_{m=1}^M \varepsilon_i^m \sigma'_m w_{hm} = \varepsilon_i^h$$

- ◇ this is previous (dense) layer error

- ◇ note, errors “propagates back”:

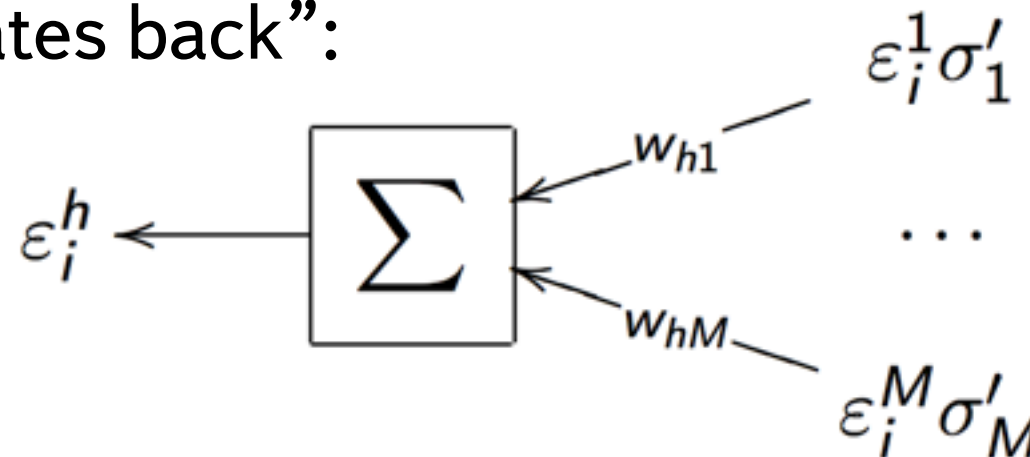

- ◇ This may be repeated further back for all layers

Stochastic Gradient Optimization

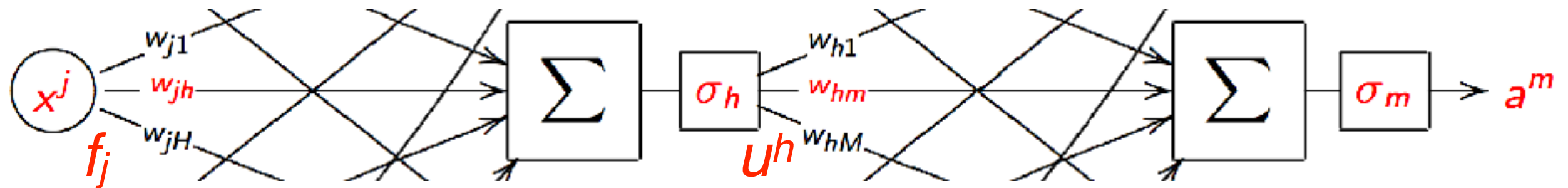

- ◇ Now we can get loss derivatives for all model parameters (weights):

$$\frac{\partial \mathcal{L}_i(w)}{\partial w_{hm}} = \frac{\partial \mathcal{L}_i(w)}{\partial a^m} \frac{\partial a^m}{\partial w_{hm}} = \varepsilon_i^m \sigma'_m u^h(x_i), \quad m = 1..M, \quad h = 0..H;$$

$$\frac{\partial \mathcal{L}_i(w)}{\partial w_{jh}} = \frac{\partial \mathcal{L}_i(w)}{\partial u^h} \frac{\partial u^h}{\partial w_{jh}} = \varepsilon_i^h \sigma'_h f_j(x_i), \quad h = 1..H, \quad j = 0..n;$$

- ◇ These are used for Stochastic Gradient Descent optimization
- ◇ NB: massive tensor computations
 - ◇ how long would it take to compute 1000D gradient numerically?
 - ◇ calculations may be significantly speed up by using vector CPU operations or loading them into GPU

Outlook

- ◇ Models and data
- ◇ Formal set of the ML problem
- ◇ Practical points
- ◇ Logistic regression
- ◇ Figures of Merit
- ◇ Models optimization
- ◇ Neural networks basics
- ◇ **Neural Networks heuristics**
 - ◇ initialization
 - ◇ dropout
 - ◇ activation function
 - ◇ batch normalization
- ◇ Decision Trees
- ◇ Illustrations
- ◇ Concluding remarks

Initialization

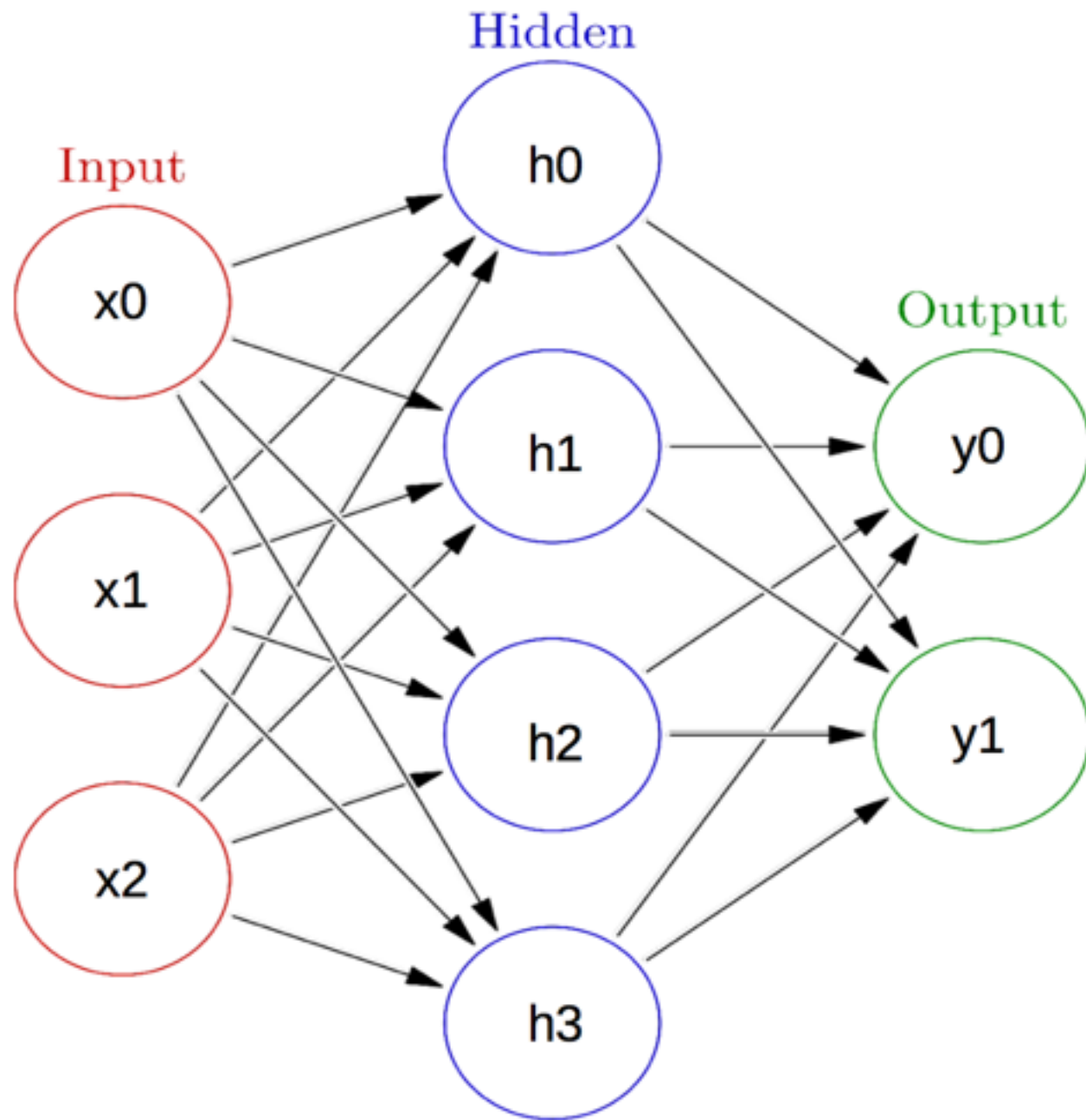

- ◇ Initialize with zeros
 - ◇ $0 \rightarrow w$
- ◇ What would be the first step?

Initialization

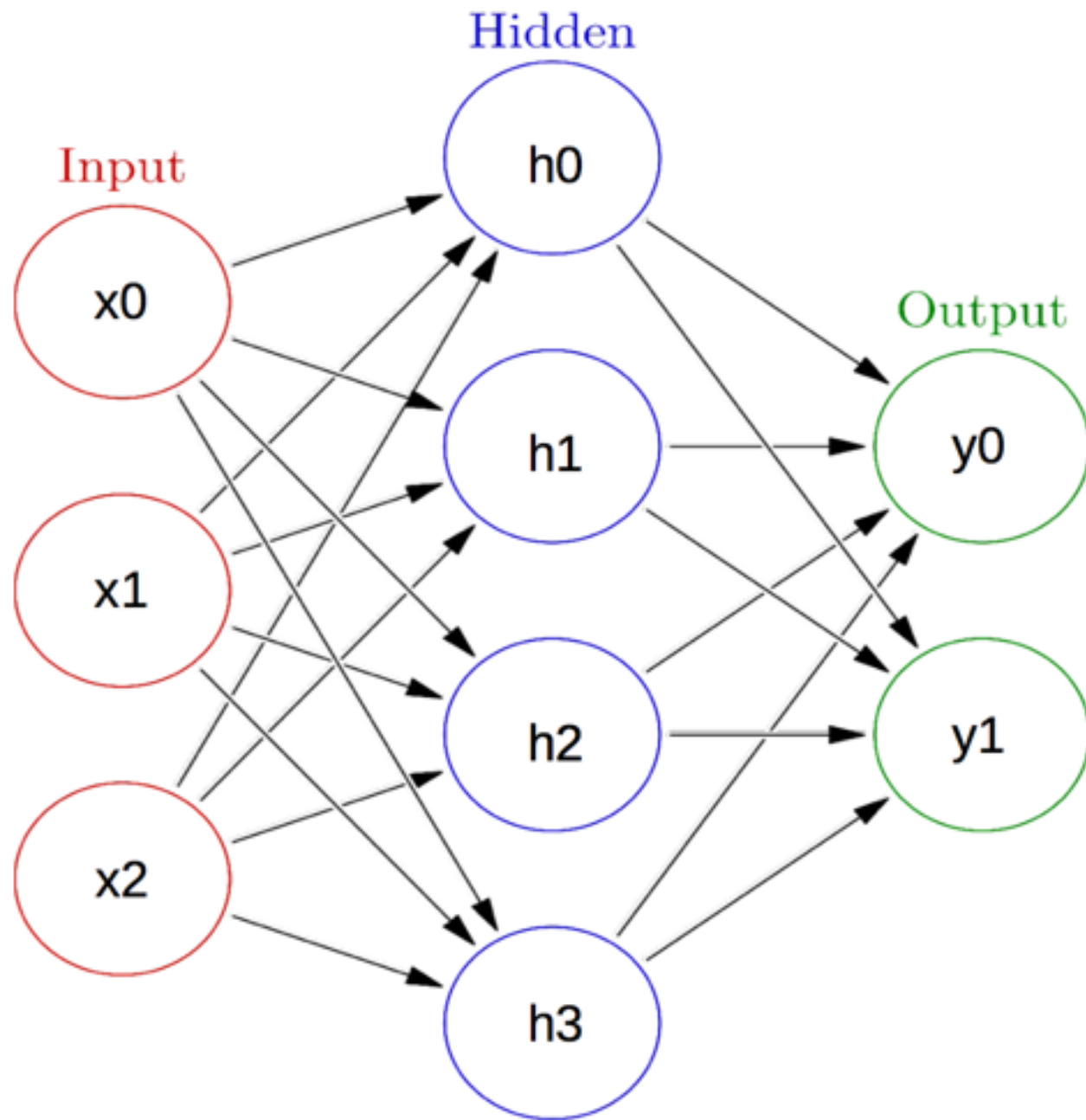

◇ Break the symmetry!

◇ $N(0, 0.01) \rightarrow w$

◇ $U(0, 0.1) \rightarrow w$

◇ ...

Dropout

- ◇ On every step of optimization disconnect neurone h of layer ℓ with probability p_ℓ :

$$x_{ih}^{\ell+1} = \xi_h^\ell \sigma_h \left(\sum_j w_{jh} x_{ij}^\ell \right), \quad P(\xi_h^\ell = 0) = p_\ell$$

- ◇ When using, enabled all neurones with correction:

$$x_{ih}^{\ell+1} = (1 - p_\ell) \sigma_h \left(\sum_j w_{jh} x_{ij}^\ell \right)$$

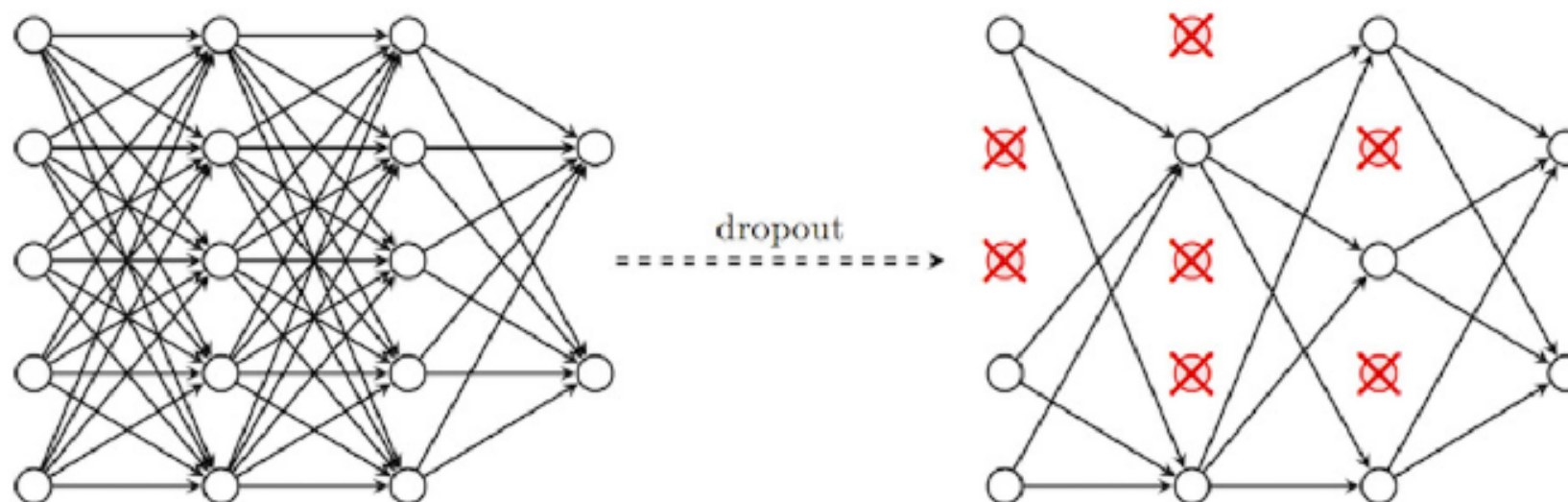

Why Dropout?

- ◇ Regularization: train NN most sustainable to losing pN neurons
 - ◇ emulating brain sustainability
- ◇ Reduce overtraining of particular network domains by forcing them all to solve general problem rather than fine tune to compensate errors each other

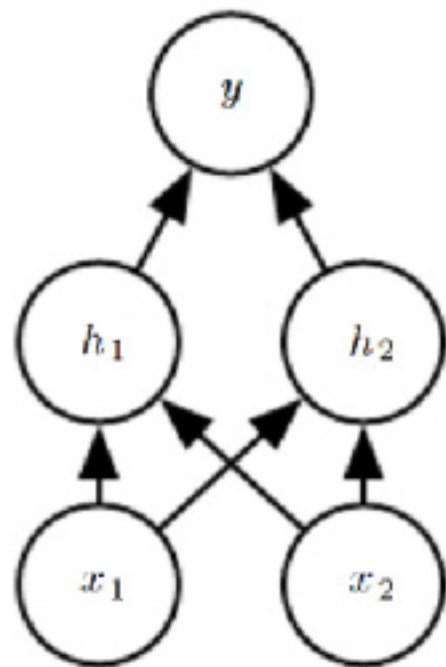

Base network

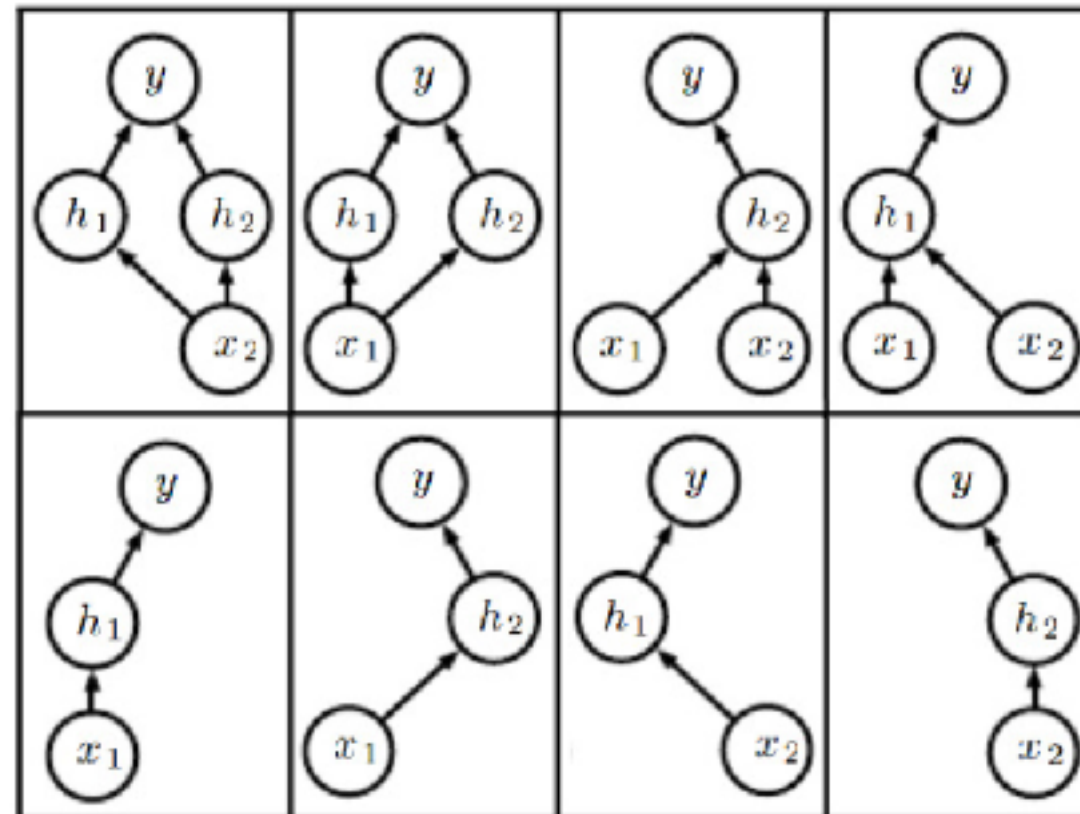

Activation Functions

- ◇ Sigmoid-like functions are prompt to “vanishing gradients” problem: may cause “network paralysis”
- ◇ Solution: using rectified linear units like

$$\text{ReLU}(y) = \max\{0, y\};$$

$$\text{PReLU}(y) = \max\{0, y\} + \alpha \min\{0, y\}$$

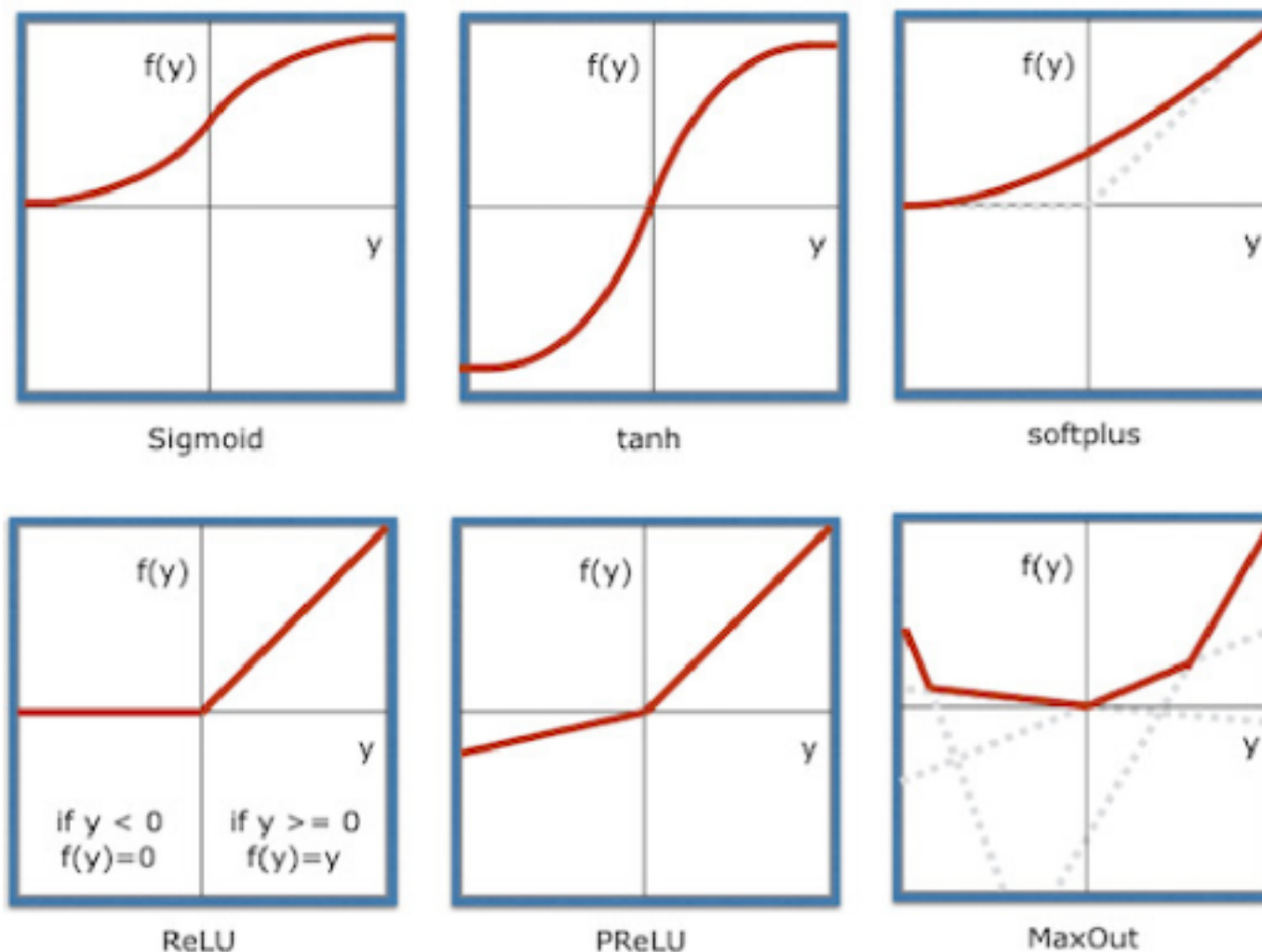

Batch Normalization

- ◇ Process data in mini-batches
- ◇ For every mini-batch normalize inputs for every neuron to given mean β and variance γ
- ◇ β_{ij}, γ_{ij} are model parameters now, learned as usual
- ◇ Heuristic: stabilising domain of input improve convergence

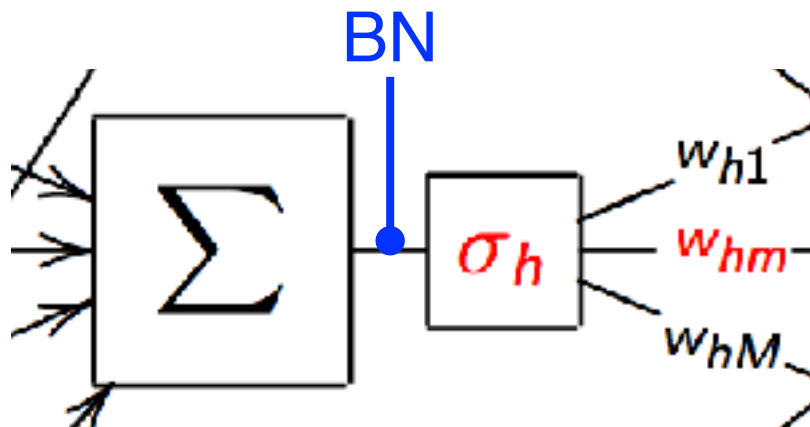

Input: Values of x over a mini-batch: $\mathcal{B} = \{x_1 \dots x_m\}$;

Parameters to be learned: γ, β

Output: $\{y_i = \text{BN}_{\gamma, \beta}(x_i)\}$

$$\mu_{\mathcal{B}} \leftarrow \frac{1}{m} \sum_{i=1}^m x_i \quad // \text{ mini-batch mean}$$

$$\sigma_{\mathcal{B}}^2 \leftarrow \frac{1}{m} \sum_{i=1}^m (x_i - \mu_{\mathcal{B}})^2 \quad // \text{ mini-batch variance}$$

$$\hat{x}_i \leftarrow \frac{x_i - \mu_{\mathcal{B}}}{\sqrt{\sigma_{\mathcal{B}}^2 + \epsilon}} \quad // \text{ normalize}$$

$$y_i \leftarrow \gamma \hat{x}_i + \beta \equiv \text{BN}_{\gamma, \beta}(x_i) \quad // \text{ scale and shift}$$

Why NN?

- ◇ For classification problems NN doing as good as BDT
- ◇ BDT even more stable
- ◇ NN power is in flexibility
- ◇ NN is a tool to build an arbitrary architecture, and as soon as appropriate loss function is set, it will learn the model eventually
- ◇ Different applications have different specifics
- ◇ you are going to have a lot of fun by studying them in coming days!

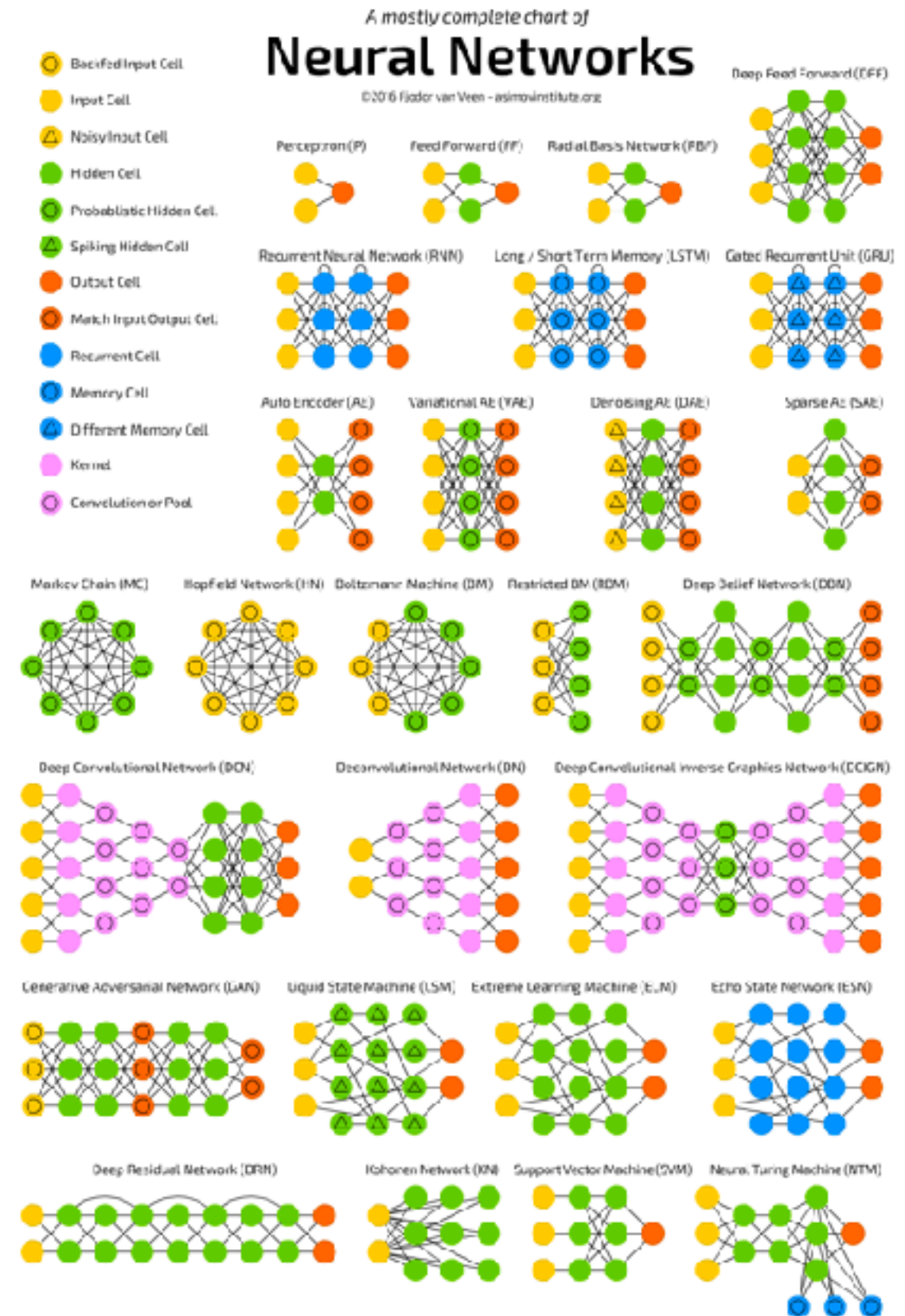

<https://towardsdatascience.com/the-mostly-complete-chart-of-neural-networks-explained-3fb6f2367464>

BDT vs NN

- ◇ Both have similar performance
 - ◇ as after meaningful training both represent the dataset properties
 - ◇ actual winner depends on data specifics
- ◇ NN are more flexible for building models beyond classification problems
 - ◇ special architecture (connections)
 - ◇ special additions to loss training function

Outlook

- ◇ Models and data
- ◇ Formal set of the ML problem
- ◇ Practical points
- ◇ Logistic regression
- ◇ Figures of Merit
- ◇ Models optimization
- ◇ Neural networks basics
- ◇ Neural Networks heuristics
- ◇ Decision Trees
- ◇ Illustrations
 - ◇ few examples
 - ◇ HEP data
 - ◇ industrial ML
 - ◇ HEP success stories
- ◇ Concluding remarks

Types of Learning

- ◇ There is well labelled data
 - ◇ we want to learn how to produce labels for more data like this
 - ◇ automation of routine
 - ◇ supervised learning
- ◇ There is labelled data, and unlabelled data which are assumed to be similar
 - ◇ we want to derive labels
 - ◇ propagation of knowledge
 - ◇ supervised learning
- ◇ There is unlabelled data with some properties
 - ◇ we want to infer some properties of this data
 - ◇ inferring new knowledge
 - ◇ unsupervised learning

(Automation of) Data Quality Monitoring

- ◇ Data quality monitoring is boring and time consuming work
 - ◇ Extremely important to guarantee solid physics results
 - ◇ Different properties of high level physics objects are analysed
 - ◇ photons, muons, calorimeter jets, combined (particle flow) jets
 - ◇ kinematics, vertices distribution
 - ◇ ~2500 features in total
 - ◇ Build classifier to decide if data are good or bad

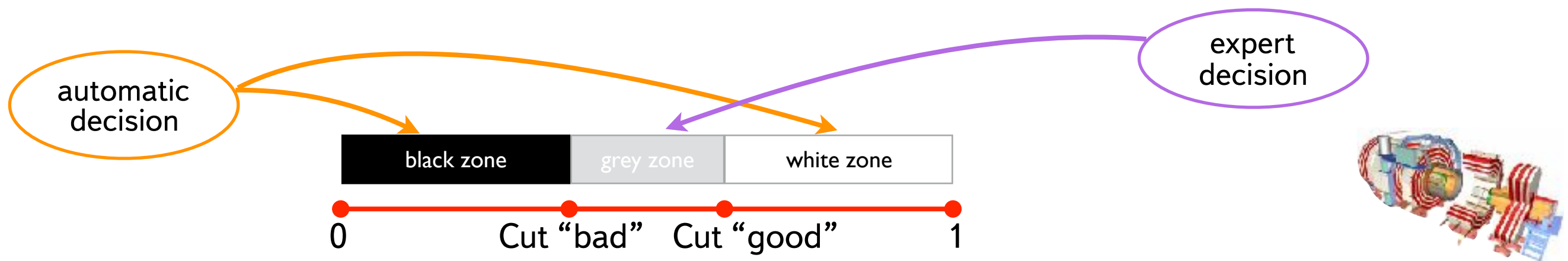
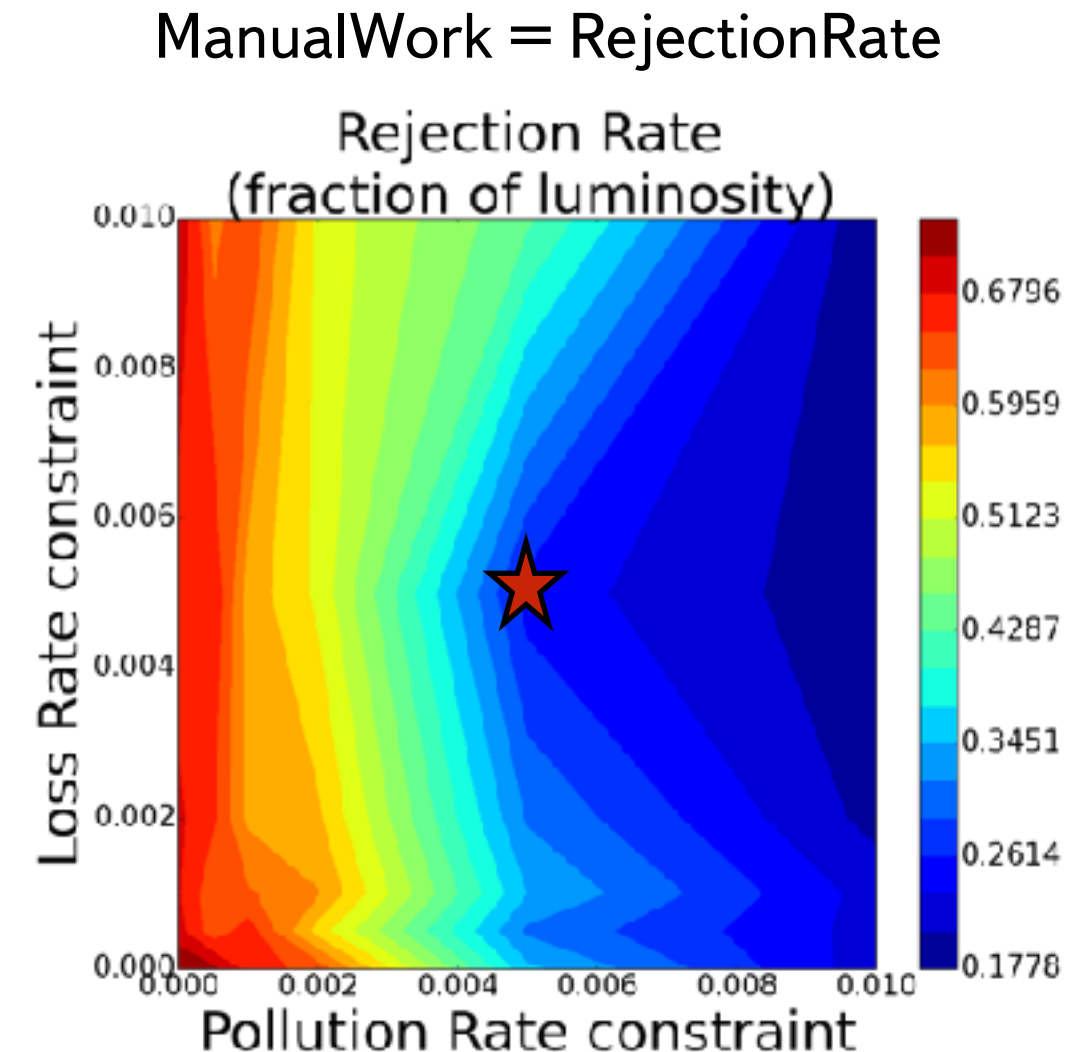

Caveat: how good the expert is?

Propagation of Knowledge

- ◇ Most common use case for HEP data analysis (MVA)
 - ◇ Train on MC or MC&DATA mixture
 - ◇ apply to data

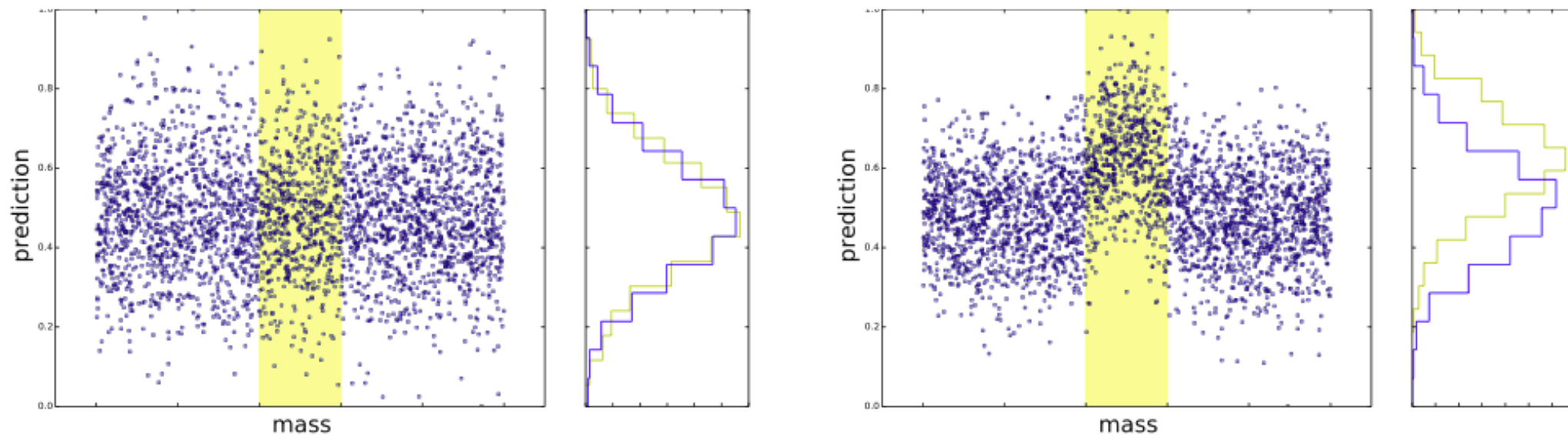

- ◇ Need to account for (minor) difference between MC and data
 - ◇ different approaches: data doping, domain adaptation etc.
 - ◇ either approach requires control sample to test the difference
 - ◇ no ML tools to propagate difference in samples into systematics in classifier

Caveat: how to determine systematics due to sample difference?

Unsupervised Learning: Dimensionality Reduction

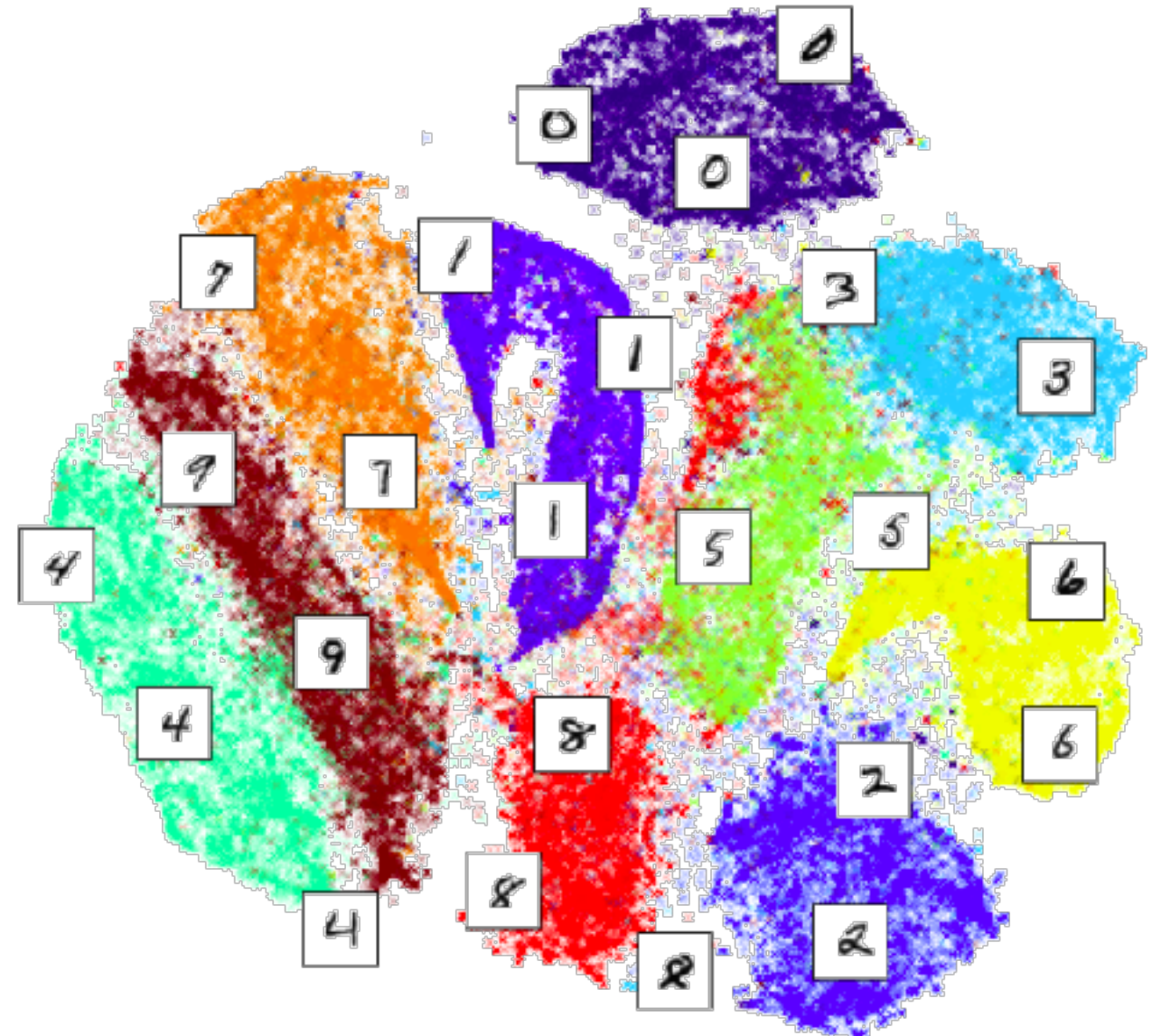

◇ Reduce $28 \times 28 = 784$ D space to 2D

◇ t-SNE algorithm effectively separates classes

Generative Models

- ◇ Learn properties of the given dataset
 - ◇ determine domain where objects of the dataset are concentrated
 - ◇ probability distributions in the domain
- ◇ Then can generate random new but similar objects
- ◇ Unconditional
 - ◇ domain for all objects (e.g. “cat on the image”)
- ◇ Conditional
 - ◇ objects are accompanied by features
 - ◇ different domains for different conditions (e.g. “red cat”)



Baseline Generator

unconditional

Generative Adversarial Network



conditional

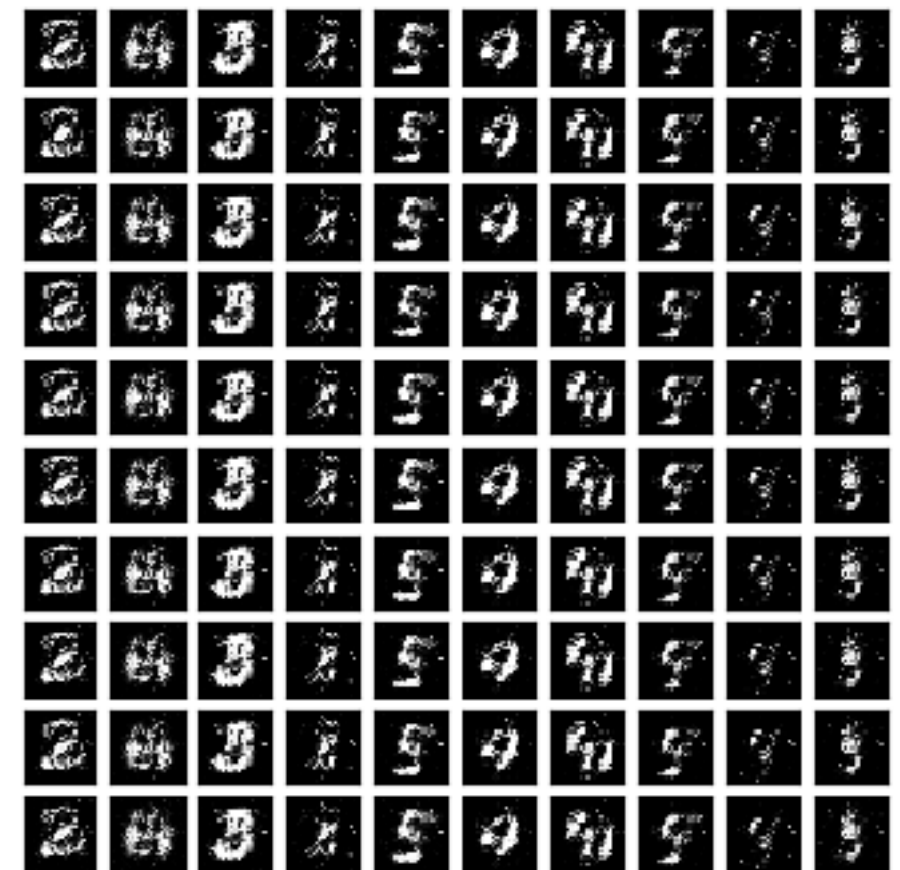
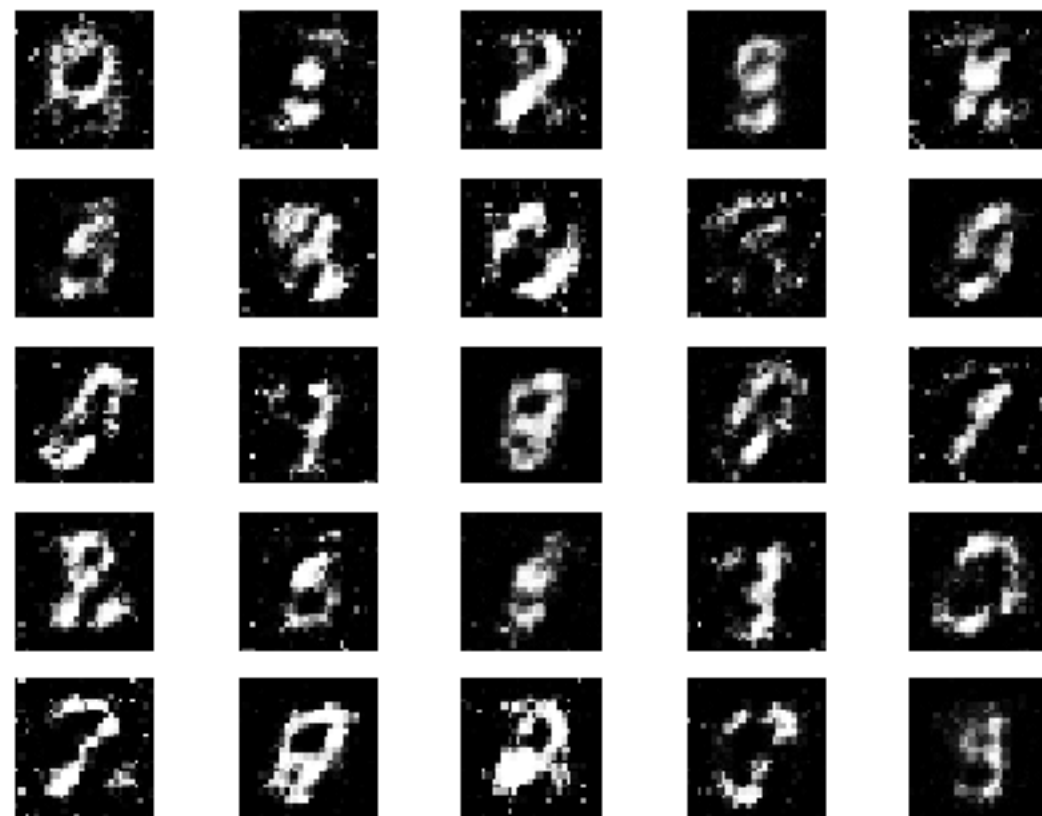

Epoch 22

Big Data Big Players

data collected in 2012

адаптировано из <http://www.wired.com/2013/04/bigdata/>

Size of data sets in terabytes	
Business email sent per year	2,986,100
Content uploaded to Facebook each year	182,500
Google's search index	97,656
Kaiser Permanente's digital health records	30,720
Large Hadron Collider's annual data output	15,360
Videos uploaded to YouTube per year	15,000
National Climactic Data Center database	6,144
Library of Congress' digital collection	5,120
US Census Bureau data	3,789
Nasdaq stock market database	3,072
Tweets sent in 2012	19
Contents of every print issue of WIRED	1.26

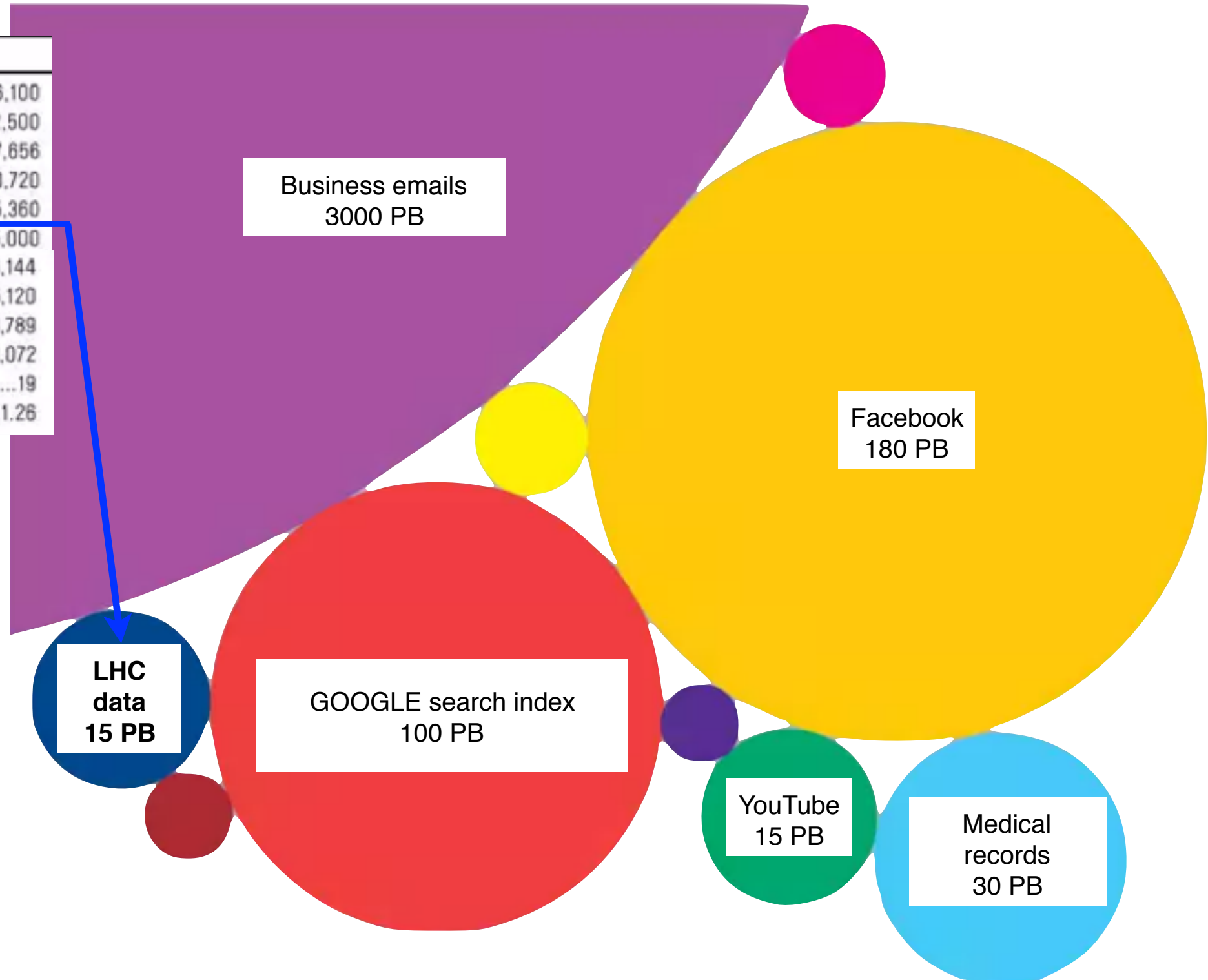

MACHINE INTELLIGENCE 3.0

ENTERPRISE INTELLIGENCE

VISUAL Orbital Insight, planet, clarifai, DEEPVISION, cortica, Igcation, SPACE_KNOW, Opticity, netra, deepomatic	AUDIO Gridspace, TalkIQ, nexidia, twitter, CAPIO, Expect Labs, Clover, Mevot, CuriousAI, pop@archive	SENSOR PREDIX, CyIoT, MAANA, Senteni, PLANET OS, UPTAKE, 3M, Refurid, thingworx, KENUX, Alluvium	INTERNAL DATA PRIMER, IBM WATSON, Dreyr, Palantir, ARMO, Alation, sapio, Outlier, Digital Reasoning	MARKET mattermark, Quid, DataFlix, PREMISE, Botfence, HOTIYA, enigma, CB Insights, Tracxn, preData
--	--	--	---	--

ENTERPRISE FUNCTIONS

CUSTOMER SUPPORT Digital Genius, Kasisto, FLOQUENT, Wiseio, ACTIONIQ, zendesk, Prond, CLARE BRIDGE	SALES collective(i), sense, fuse machines, AVISO, salesforce, INSIDE SALES.COM, clari, Zenight	MARKETING HINTIGO, Lattice, RADIUS, LiftIgniter, [PERSADO], brightfwd, retention, COGNICOR, AUPHIX, TAGM	SECURITY CYCLANCE, DARKTRACE, ZIMPERIUM, deepinstinct, Sentinel, NEMISO, graphistry, drawbridge, SignalSoc, AppZen	RECRUITING textio, entelo, Wade & Wandy, hi, unitive, SpringRole, GIGSTER, HireVue
--	--	--	--	--

AUTONOMOUS SYSTEMS

GROUND NAVIGATION drive.ai, AdasWorks, ZOOX, Mobileye, UBER, Google, Tesla, nuTonomy, Auto Robotics	AERIAL SKYDIO, SHIELD AI, Airware, DJI, LILY, DroneDeploy, pLora, SKYCATCH	INDUSTRIAL JAYBRIDGE, OSARO, CLEARPATH, fetch, KINDRED, rathink robotics, HARVEST	PERSONAL amazonalexa, Cortana, Allo, facebook, Siri, Replika	PROFESSIONAL butter.ai, pogo, SKIPFLAG, clara, x.ai, slack, talla, Zoom, sudo
---	--	---	--	---

INDUSTRIES

AGRICULTURE BLUEWATER, MAVIX, tule, TRACTOR, Pivo, Jerrison, ABB-DATA, Descartes Labs, ud, abuday	EDUCATION KNEWTON, volley, gradescope, CTI, coursera, UUDACITY, school	INVESTMENT Bloomberg, sentiment, ISENTIUM, KENSHO, alphaSense, Dataminr, CERBERIUM CAPITAL, Quandl	LEGAL blueJ, BEAGLE, Everlaw, RAVEL, seal, ROSS, LEGAL ROBOT	LOGISTICS NAUTO, Acera, PRETEOKT, Routific, clearmetal, MARBLE, PITSTOP
---	--	--	--	---

INDUSTRIES CONT'D

MATERIALS zymergen, Citrine, Eigen Innovations, SIGHT MACHINE, 3DHO, nanotronics, CALCULARIO	RETAIL FINANCE TALA, best finance, Lendo, earnest, affirm, MIRADOR, wealthfront, Bettermort	PATIENT PULSE, CareSkore, ZEPHYR HEALTH, Watson Health, Cnc360, SENTIENT, Atcorwise, Numerale	IMAGE butterfly, 3SCAN, ARTERYS, onlitic, BAYLABS, imagia, Google DeepMind	BIOLOGICAL iCarbonX, color, GRAIL, deep genomics, RECURSION, ILLUMINIST, Numerate, Atomwise, verily, 21ST
--	---	---	--	---

TECHNOLOGY STACK

- AGENT ENABLERS**
 OCTANE.AI, howdy, Maluba, KITT.AI, OpenAI Gym, Kasisto, AUTOMAT, semanticmachines
- DATA SCIENCE**
 DOMINO, SPARKBEYOND, rapidminer, kaggle, DataRobot, yhat, AYASDI, datafai, seldon, yscop, bigml
- MACHINE LEARNING**
 CognitiveScale, GoogleML, context, relevant, Dycorp, HyperScience, nana, ogics, minds.ai, H2O.ai, SCALED INFERENCE, sparkcognition, loop, GEOMETRIC INTELLIGENCE, deepsense.io, reactive, skymind, bonsai
- NATURAL LANGUAGE**
 agola, RYLIEN, LEXALYTICS, Narrative Science, loop, spaCy, LUMINOSO, cortical.io, MonkeyLearn
- DEVELOPMENT**
 SIGOPT, HyperOpt, fuzzyio, pkite, rainforest, lobe, Anodot, Signifai, LAYER 6, bonsai
- DATA CAPTURE**
 CrowdFlower, diffbot, CrowdAI, import.io, Paxata, DATASIFT, amazon, mechanicalturk, enigma, WorkFusion, DIALOGUE, TRIFACTA, persehub
- OPEN SOURCE LIBRARIES**
 Keras, Chainer, CNTK, TensorFlow, Caffe, H2O, DEEPLARNING4J, theano, torch, DSSTNE, scikit-learn, AzureML, neon, MXNet, DMTK, Spark, PaddlePaddle, WEKA
- HARDWARE**
 KNUPATH, TENSTORRENT, Cirrascale, NVIDIA, nvidia, nervana, Movidius, tensilica, GoogleTPU, 10th Labs, Qualcomm, Cerebras, Isosemi
- RESEARCH**
 OpenAI, KNOCCN, maibee, ELEMENT, vicarious, Numenta, Kimera Systems, CogitAI

shivonzlls.com/MACHINEINTELLIGENCE · Bloomberg BETA

Domain Relevant for Science

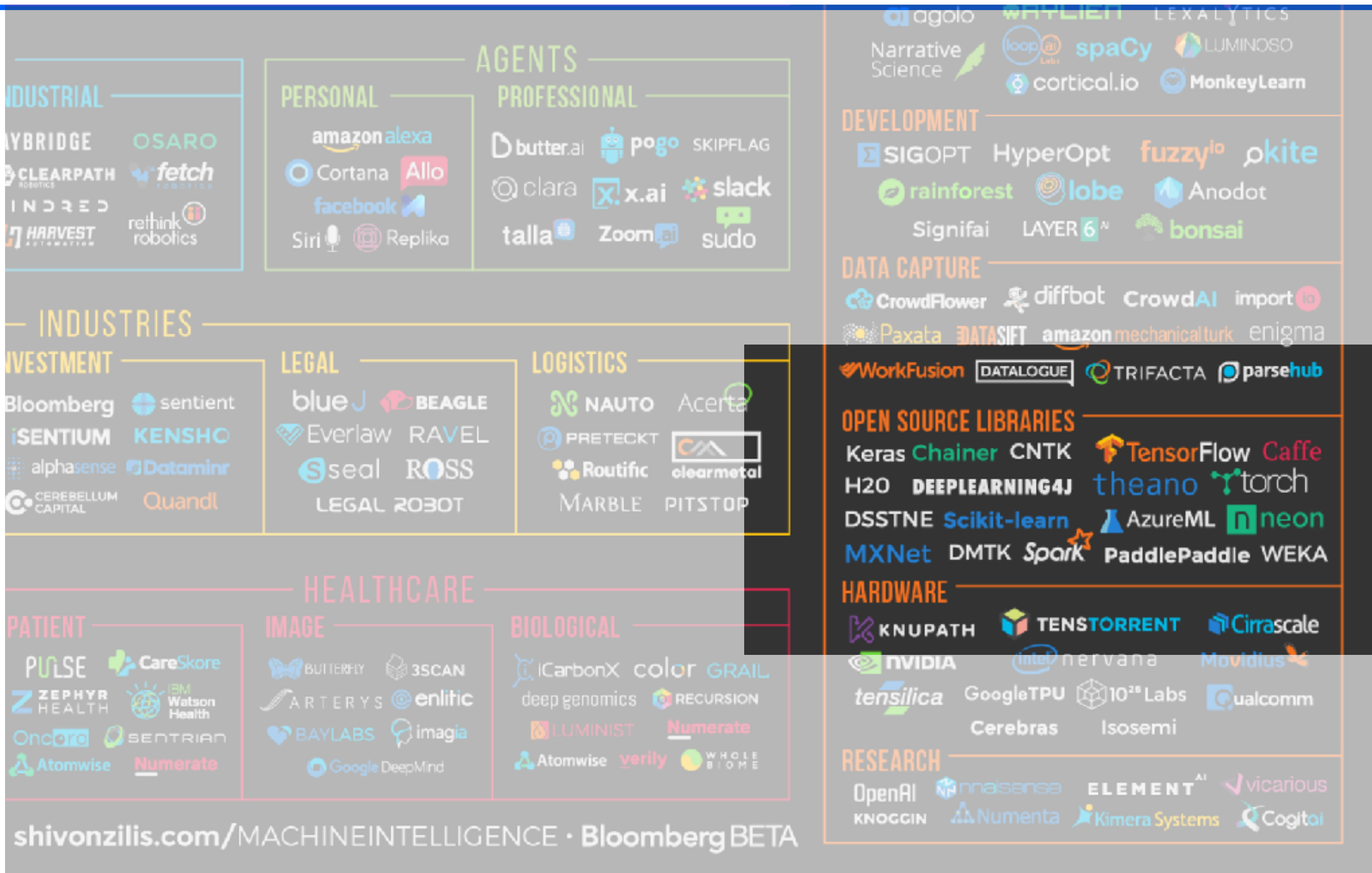

shivonzilis.com/MACHINEINTELLIGENCE · Bloomberg BETA

Generative Models in Cosmology

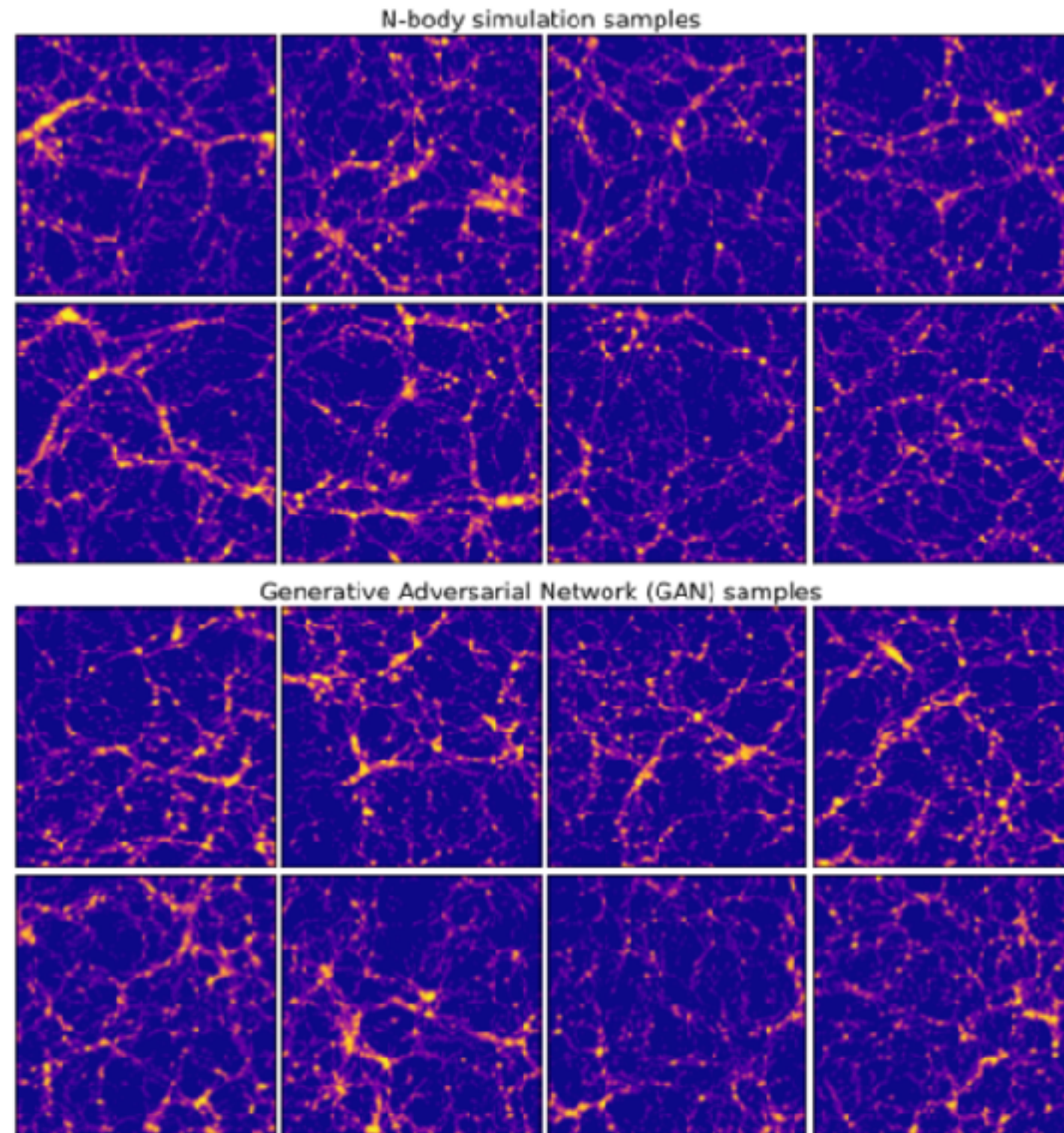

Rodríguez et al,
arXiv:1801.09070

Figure 3: Samples from N-body simulation (top two rows) and from GAN (bottom two rows) for the box size of 100 Mpc. In this figure, transformation S1 with $k = 7$ was applied.

Success Stories: LHCb Trigger

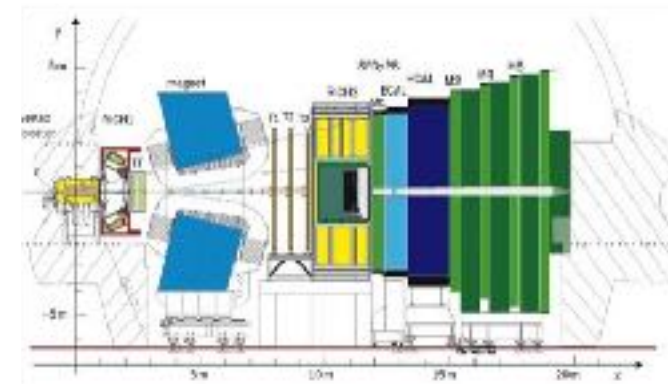
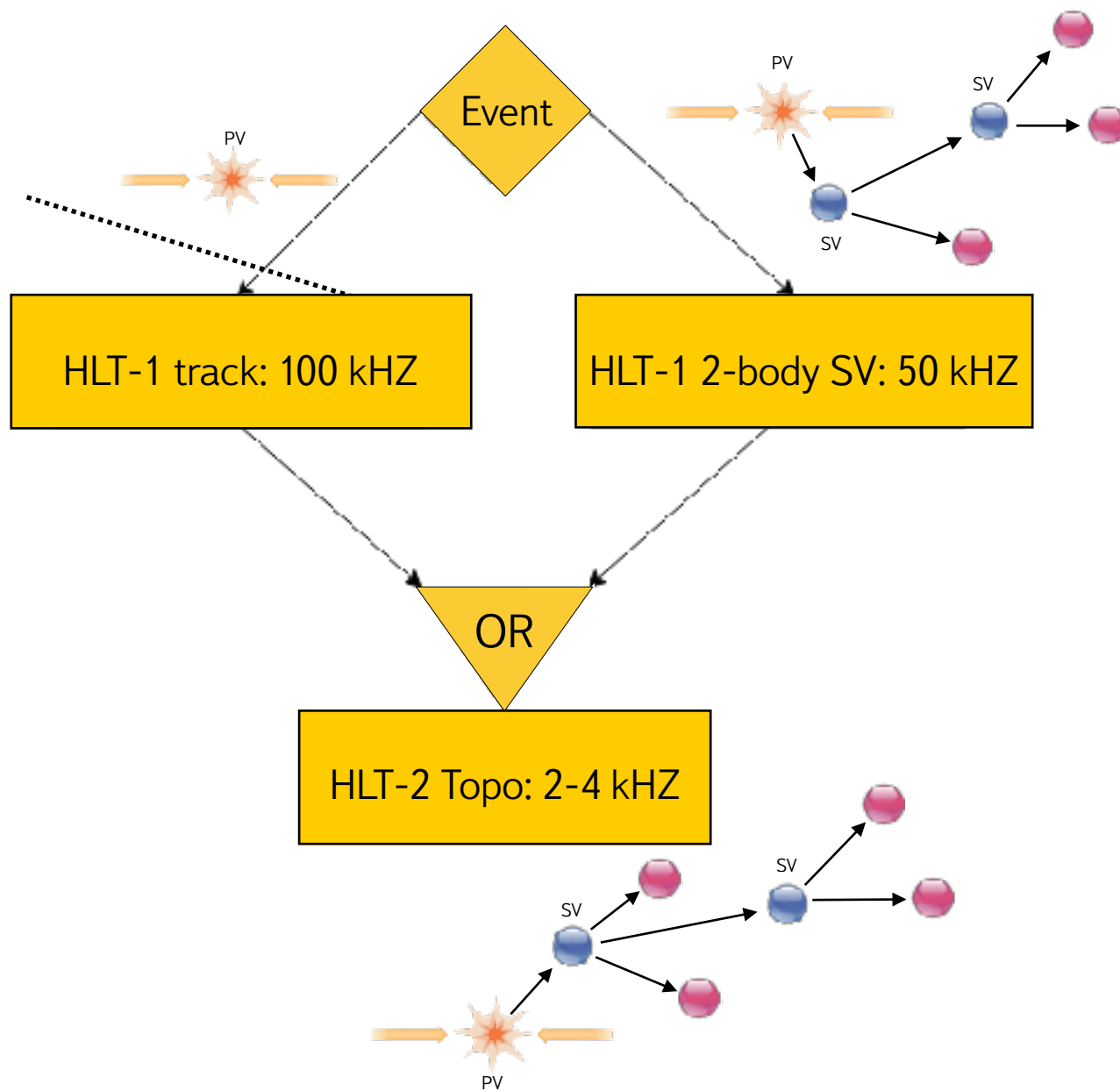

mode	2.5 kHz	4. kHz
$B^0 \rightarrow K^*[K^+\pi^-]\mu^+\mu^-$	1.64	1.72
$B^+ \rightarrow \pi^+K^-K^+$	1.59	1.65
$B_s^0 \rightarrow D_s^-[K^+K^-\pi^-]\mu^+\nu_\mu$	1.14	1.47
$B_s^0 \rightarrow \psi(1S)[\mu^+\mu^-]K^+K^-\pi^+\pi^-$	1.62	1.71
$B_s^0 \rightarrow D_s^-[K^+K^-\pi^-]\pi^+$	1.46	1.52
$B^0 \rightarrow D^+[K^-\pi^+\pi^+]D^-[K^+\pi^-\pi^-]$	1.40	1.86

- ◇ Aggressively re-optimised topological trigger for Run II operation
- ◇ Gain 10%..70% efficiency for different channels!

SS: MicroBooNE Neutrino Selection

Nature, 560, 41-48 (2018)

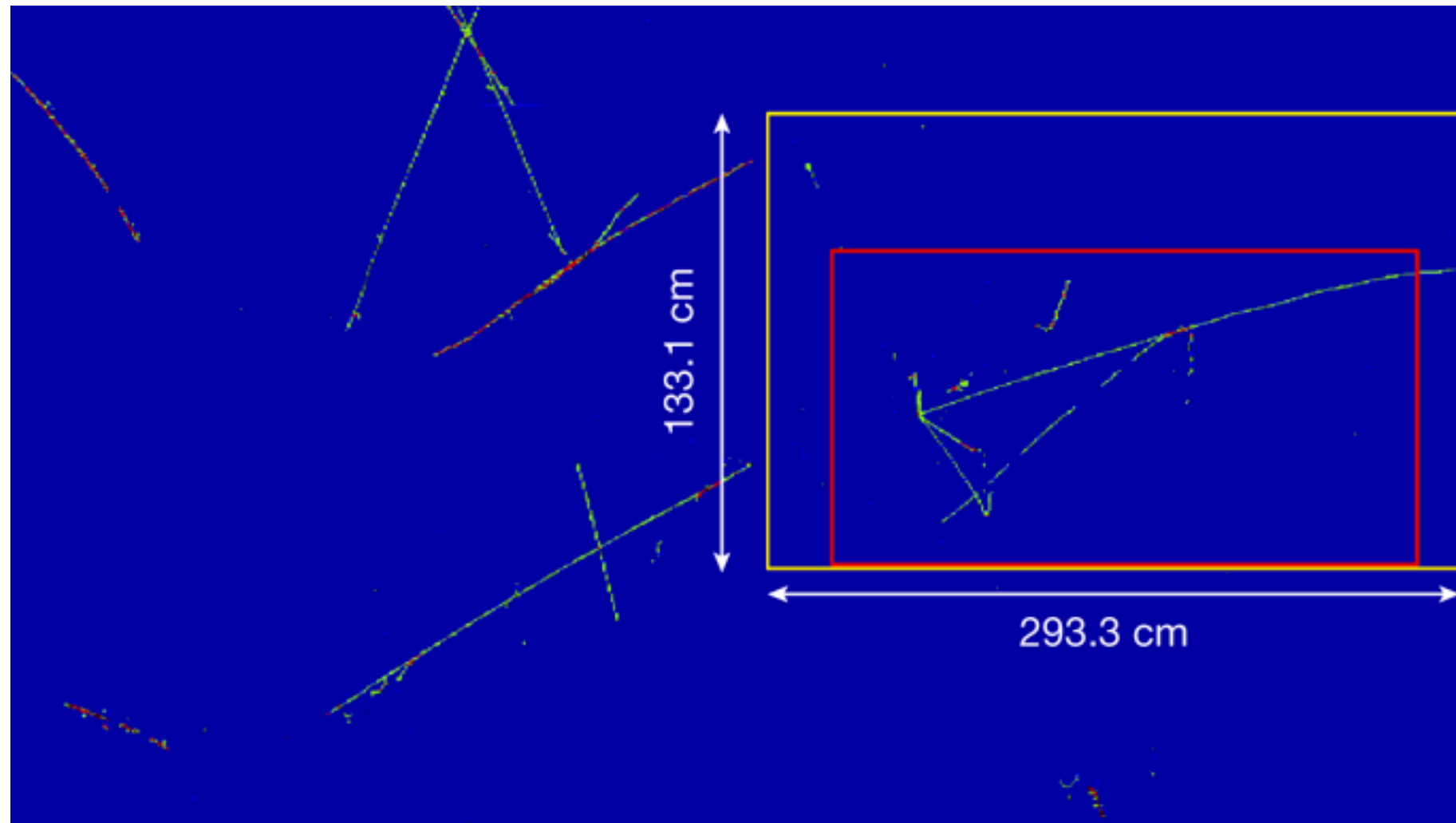

- ◇ CNN effectively predicts bounding box containing interacting neutrino

SS: NOvA Event Selection

Nature, 560, 41-48 (2018)

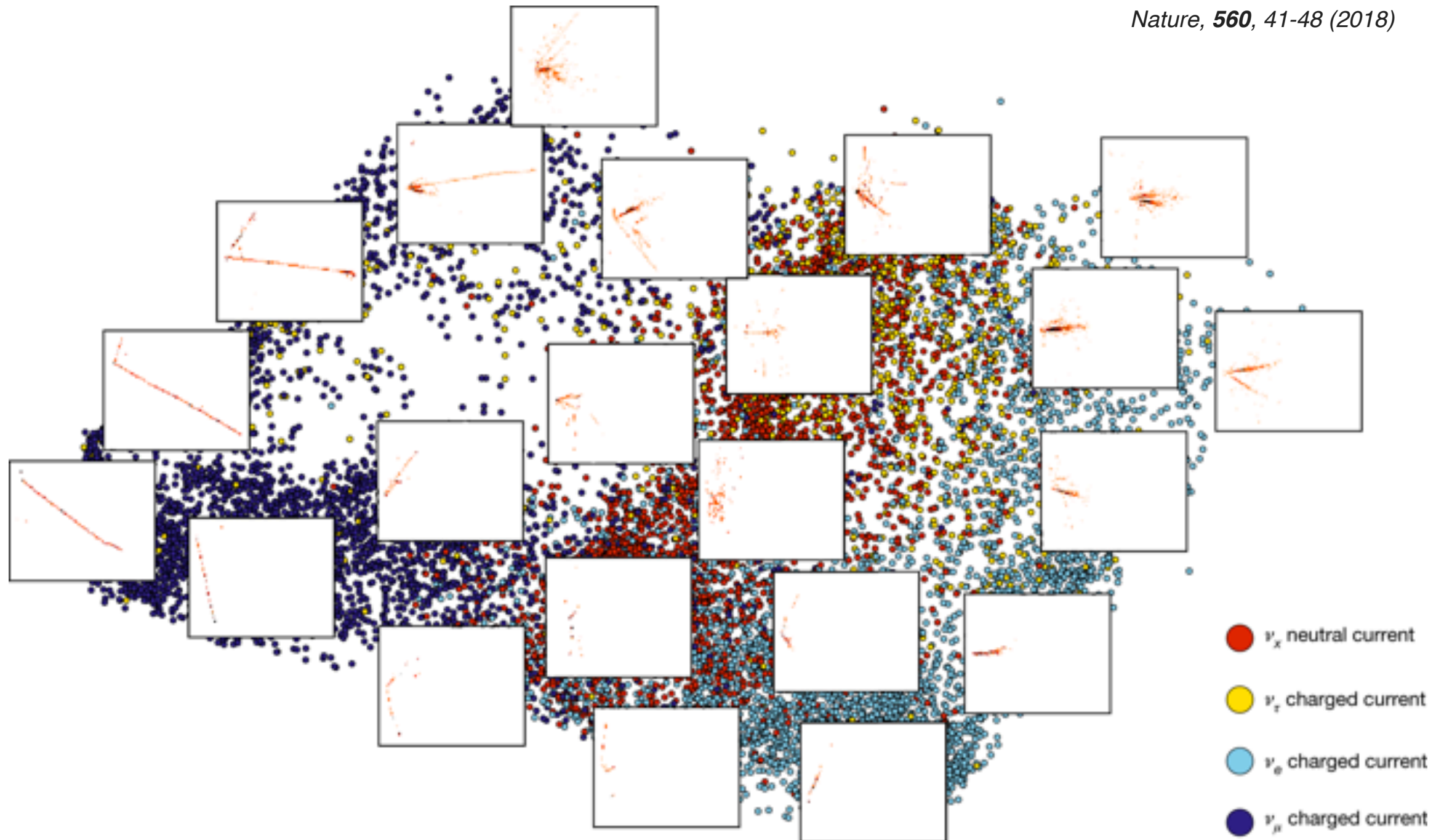

- ◇ Classification of different types of different neutrino interactions

Outlook

- ◇ Models and data
- ◇ Formal set of the ML problem
- ◇ Practical points
- ◇ Logistic regression
- ◇ Figures of Merit
- ◇ Models optimization
- ◇ Neural networks basics
- ◇ Neural Networks heuristics
- ◇ Decision Trees
- ◇ Illustrations
- ◇ **Concluding remarks**

Evolution of HEP x ML Engineering

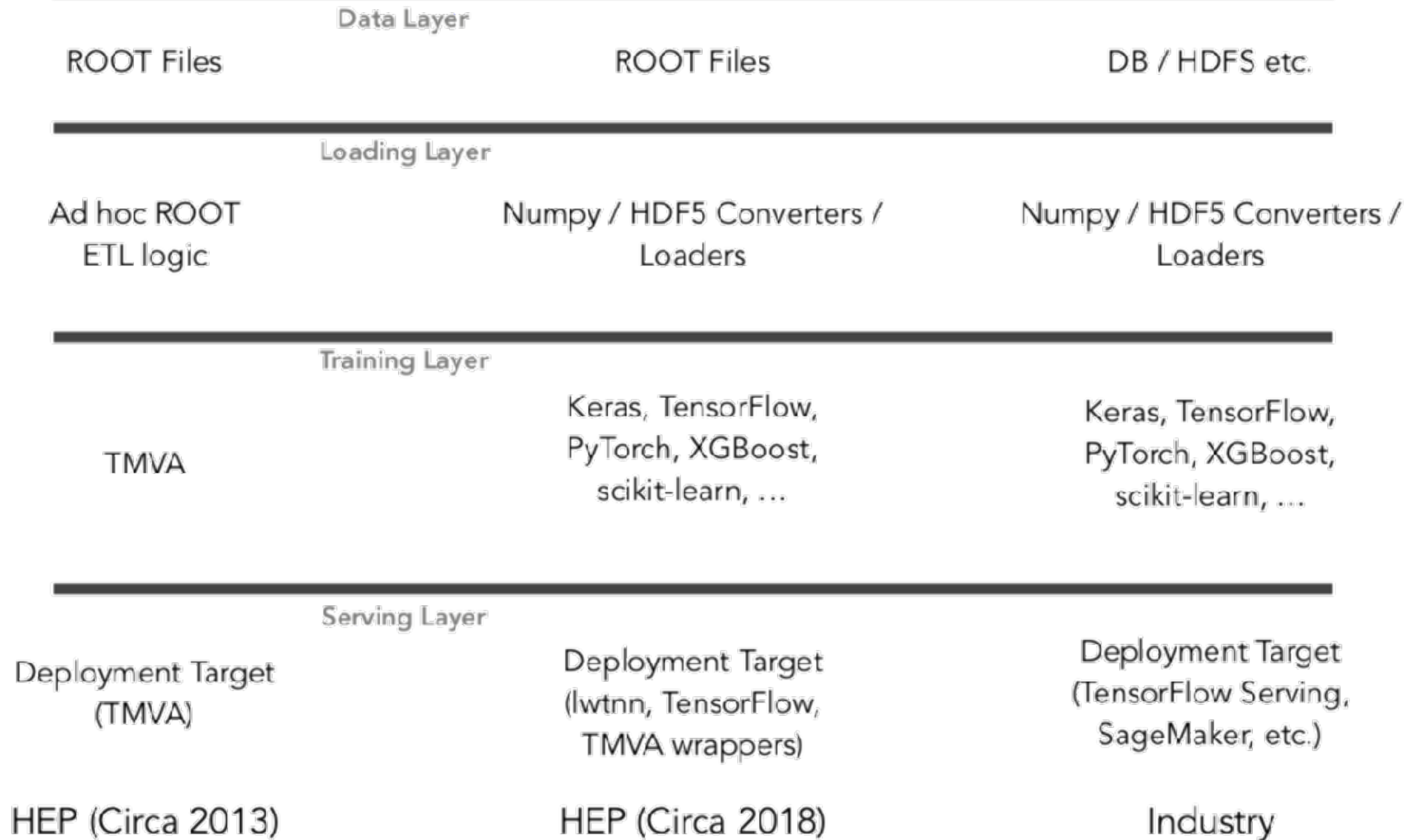

Conclusions

- ◇ Machine Learning **is not** just glorified statistics
 - ◇ though it is strongly related to it
- ◇ Machine Learning is about
 - ◇ **representation**
 - ◇ art of converting data to the format suitable for processing by algorithms
 - ◇ **evaluation**
 - ◇ writing a good loss function that effectively converts data into answer of interest
 - ◇ **optimization**
 - ◇ govern the system to develop in the right direction and converge to the right point

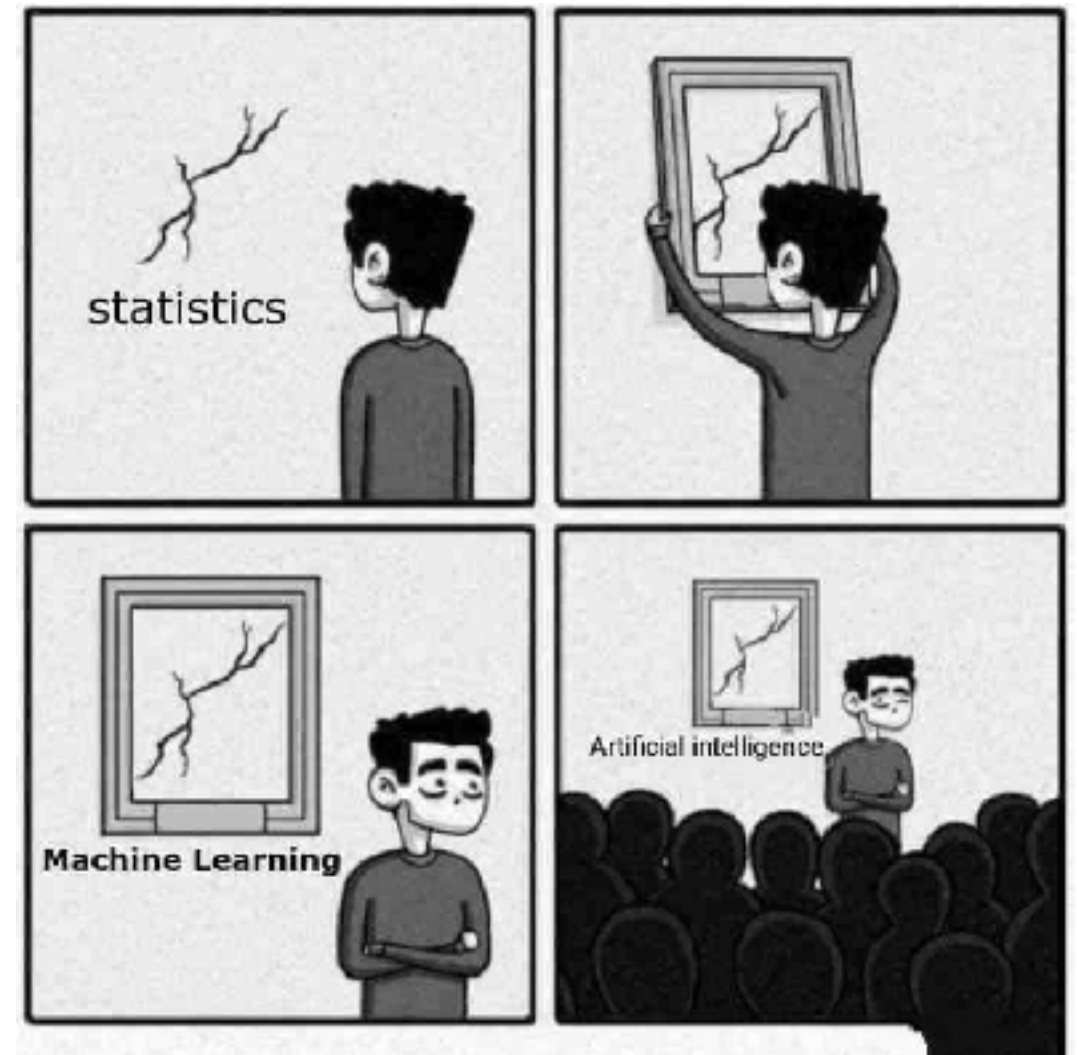

<https://towardsdatascience.com/no-machine-learning-is-not-just-glorified-statistics-26d3952234e3>